



# PORTABLE GAS BBQ



FCC-G-20500-00 / FCC-G-20500-25 / PB-2500-VW01

## USER MANUAL:

Instructions, maintenance and safety

**OUTDOOR USE ONLY**  
READ THE MANUAL, FOLLOW THE ASSEMBLY INSTRUCTIONS STEP BY STEP. GET TO KNOW YOUR BARBECUE AND THE SAFETY INSTRUCTIONS BEFORE USING THE APPLIANCE!



### WHO ARE WE?

The Flying Culinary Circus is the world's first traveling cooking group. In 2005 Trond, Hans-Kristian, Mathias, and Tor, went to New York. A journey that ended up being an adventure of a lifetime. With 65 countries and 300,000 hours of culinary experience in the Chef whites, we have developed, designed, and produced a wide range of grills and accessories that add something new and unique to the grill range in the Nordic region.

Something we have always had is great love for grilling and barbeque as a cooking method. Whether we have a garden party, enjoy summer evenings in the park, cater for famous guests on the French Riviera or simply just go on a cabin trip, barbecue and grilling is in the center. It's fantastic flavors, it's tough, it's cool and it's love for the most amazing cooking method in the world!

2023 will be the sixth year for FCC BBQ, and we're very proud and humble for the success and what we as a company have achieved. For all of FCC BBQ products, the common denominator is high quality and functionality at a good price. We want to inspire the world through cooking. Just as our vision: Share the fun of cooking!

# FCC BBQ

*by The Flying Culinary Circus*



Hans-Kristian, Mathias, Trond and Tor



---

The story of FCC.....	2
Warnings .....	5
Technical Data .....	6
Parts List .....	7
Gas Cartridge .....	8
Operating Instructions .....	9
Recipe .....	14
Troubleshooting .....	15
Consumer Contact .....	16

THIS APPLIANCE SHALL ONLY BE USED WITH 220 GRAM BUTANE CARTRIDGES. WE RECOMMEND:



- FCC GRAB'N'GRILL ITEM NO. : FCC-GB-501401

- FOR OUTDOOR USE ONLY
- DO NOT USE IN DIRECT SUNLIGHT.
- KEEP BOTTOM AWAY FROM DIRT AND SAND.
- THIS GRILL MUST ALWAYS BE OPERATED ON A HORIZONTAL, SECURE AND STEADY SURFACE.  
DO NOT USE THE GRILL ON TOP OF THE PLASTIC CASE!
- DO NOT MODIFY THE APPLIANCE.
- ACCESSIBLE PARTS BECOME VERY HOT DURING USE. KEEP CHILDREN AND OTHERS IN NEED FOR SUPERVISION AT A DISTANCE WHEN USING THE GRILL.
- DO NOT SPRAY AEROSOLS IN THE VICINITY OF THIS UNIT WHILE IT IS IN OPERATION.
- DO NOT LEAVE THE GRILL UNATTENDED WHILE OPERATING.
- AVOID TOUCHING BURNER, TRIVET ETC. IMMEDIATELY AFTER USE OR WHILE IN USE.
- THIS GRILL SHALL BE USED AWAY FROM FLAMMABLE MATERIALS AND INFORMATION ON MINIMUM DISTANCE 30 CM FROM ADJACENT SURFACES (WALL, CEILING).
- IF THIS PRODUCT SHOULD DEVELOP A FAULT PLEASE RETURN TO PLACE OF PURCHASE ALONG WITH GUARANTEE ENSURING THE GUARANTEE DETAILS ABOVE ARE FILLED IN CORRECTLY.  
UNDER NO CIRCUMSTANCES SHOULD YOU ATTEMPT TO REPAIR THIS APPLIANCE OR TAMPER WITH ANY OF THESE PARTS.
- DO NOT USE THE APPLIANCE IF IT HAS DAMAGED OR HAVE WORN SEALS; DO NOT USE IF LEAKING, DAMAGED OR IF IT DOES NOT OPERATE PROPERLY.
- DO NOT LEAN OVER THE GRILL WHILE IGNITING. A SMALL AMOUNT OF "FLARING" MAY OCCUR FOR 2-3 SECONDS WHEN FIRST IGNITING, WHICH IS DUE TO GAS PRESSURE BUILD-UP.

**Total Heat input:** 2.4kW

**Gas consumption:** 174 gram/hour

**Casette gas cartridge (not included):** This appliance category is Direct Pressure Butane and should only be used with a 220g butane gas cartridge or compatible alternative that complies to EN417.

VALVE SIZE	GAS TYPE	GAS CATEGORY
0.59 mm main burner.	Butane gas	Vapor pressure butane

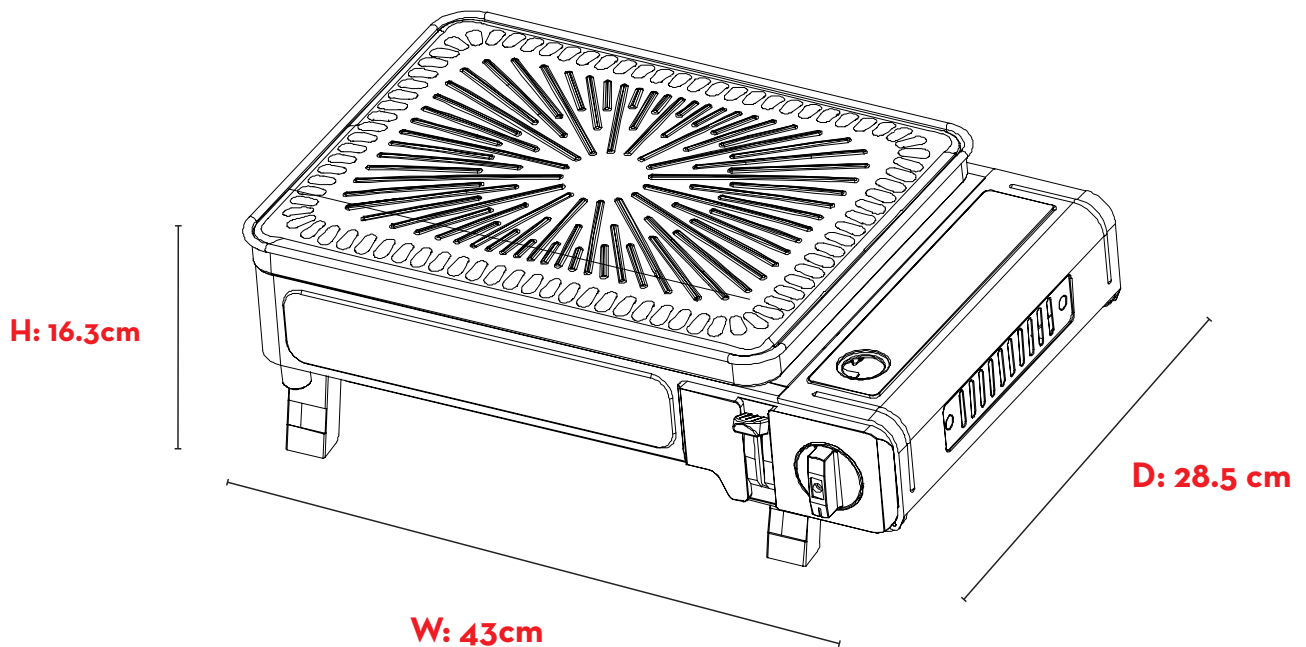

**CE 1336-23**

The product is manufactured in accordance with European Gas Appliances Regulation (EU) 2016/426



**ONLY THE GAS TYPE AND GAS CATEGORY LISTED IN THE RATING LABEL SHOULD BE USED ON YOUR APPLIANCE.**

**WE RECOMMEND USING GRAB'N'GRILL CASSETTE GAS.**

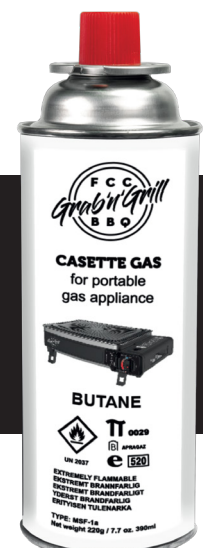

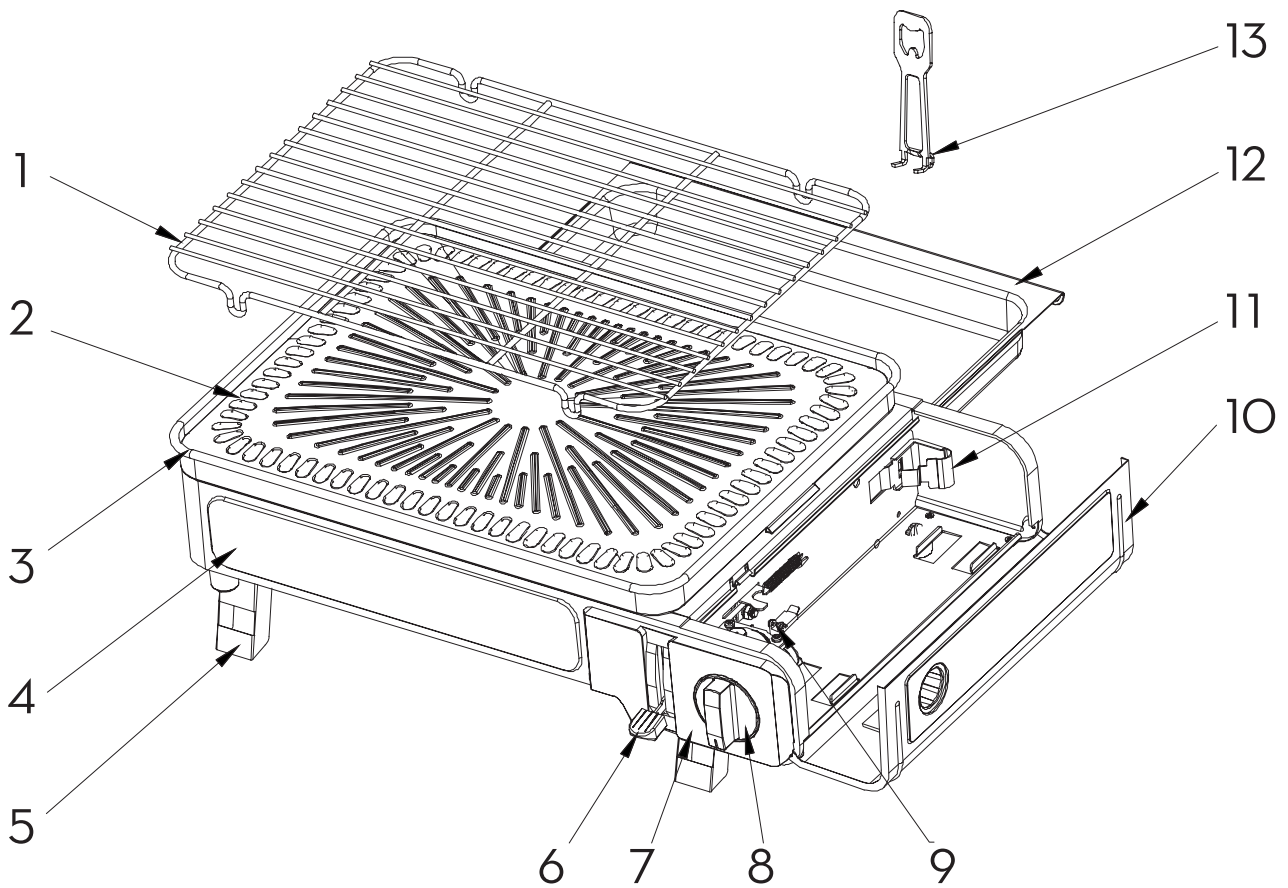

1 COOKING GRATE

2 COOKING PLATE

3 HEAT TENT

4 FIREBOX

5 FOLDABLE LEG

6 GAS CANISTER AND RELEASE LEAVER

7 DECORATIVE PLATE

8 CONTROL KNOB

9 VALVE ASSEMBLY

10 COVER OF GAS CARTRIDGE

11 GAS CARTRIDGE LOCATION LUG

12 GREASE TRAY

13 BOTTLE OPENER / LIFTING TOOL





**THIS APPLIANCE CATEGORY IS DIRECT PRESSURE BUTANE AND SHOULD ONLY BE USED WITH A BUTANE GAS CARTRIDGE OR COMPATIBLE ALTERNATIVE THAT COMPLIES TO EN417.**

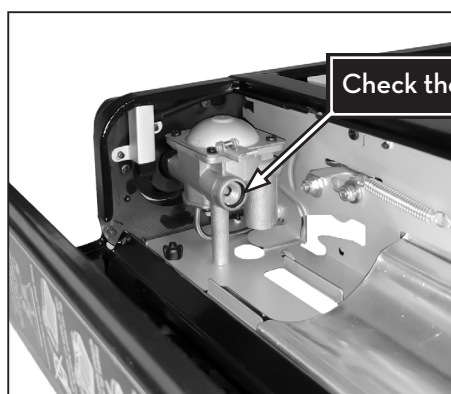

Check the seal regularly!

When replacing or removing a cartridge check that seals (between cartridge and appliance) are in place and in good condition.

Dispose of used cartridges safely. Never puncture or dispose of in fire.

- Check the seals (between the appliance and the gas canister) are in place and in good condition.  
Do not use the appliance if it has damaged or worn seals, do not use an appliance which is leaking, damaged or which does not operate properly.
- If there is a leak on your appliance (smell of gas), take it outside, immediately into a well ventilated location where the leak may be detected and stopped.  
If you want to check the leak. Do it outside, do not try to detect leaks using a flame, use soapy water.
- Butane gas has poor combustion ability at low temperatures. At a temperature lower than 10 °C, this could affect whether the grill can be lit and how hot it gets.

## CAUTION ON THE CARTRIDGE

1. The cartridge should be placed away from flammable products or the direct rays of the sun. Be sure to close the tap securely after using. Never keep cartridges in places over 40°C.
2. Do not store unit or cartridge in enclosed areas.
3. Do not puncture or incinerate empty cartridge.
4. Do not refill gas into empty can.
5. Keep out of the reach of children.
6. When you change the cartridge, check the cartridge is empty before changing it (shake to hear the noise made by the liquid).
7. This appliance shall be used away from flammable material (include distances recommend) from walls etc.
8. The cartridges shall be changed in a well-ventilated location, outside, away from any sources of ignition such as naked flames, pilots, electric lines and away from other people.





THESE INSTRUCTIONS ARE DESIGNED FOR YOUR BENEFIT WE STRONGLY RECOMMEND THAT YOU READ THEM CAREFULLY BEFORE USING YOUR NEW BBQ .

ONCE YOU HAVE FAMILIARISED YOURSELF WITH THE OPERATION AND CARE OF THIS GRILL, PLEASE KEEP THIS MANUAL IN A SAFE PLACE FOR FUTURE REFERENCE.

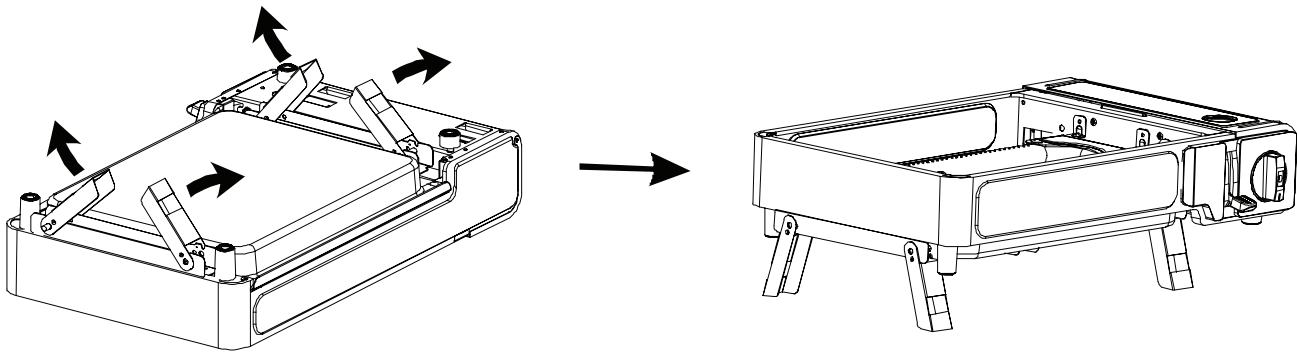

## UNFOLD THE LEGS ON THE GRILL BEFORE USE!

Ensure grill is placed on a flat level surface when in use.

Do not place grill on any flammable surface such as a wooden table or any surface that can be damaged by heat.

# 1

Fitting gas cartridge, ensure the control knob (8) is in the off position and the cartridge release lever (6) is in its release position (Unlock).

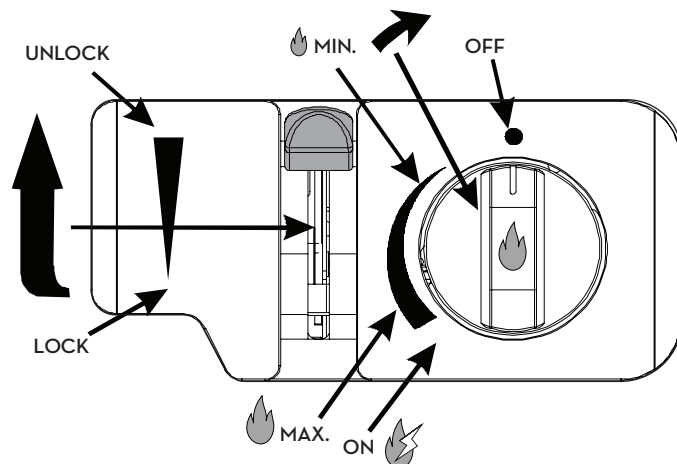

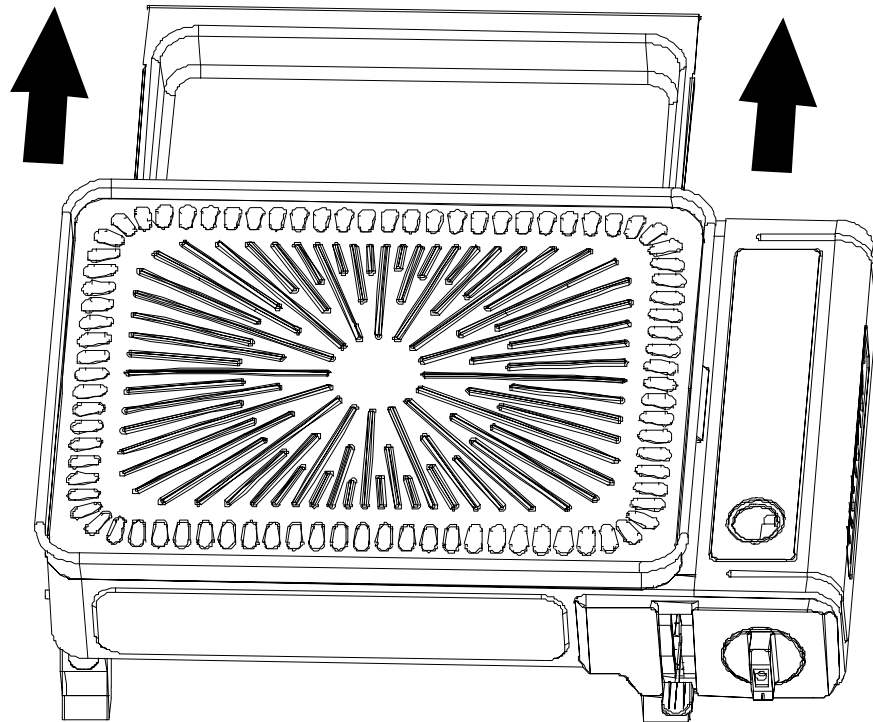
**2**

Pour about 800ml of water to “grease tray” and put in the right position before ignition.

The water will make cleaning of the grease tray more convenient and secure against overheating against the ground.

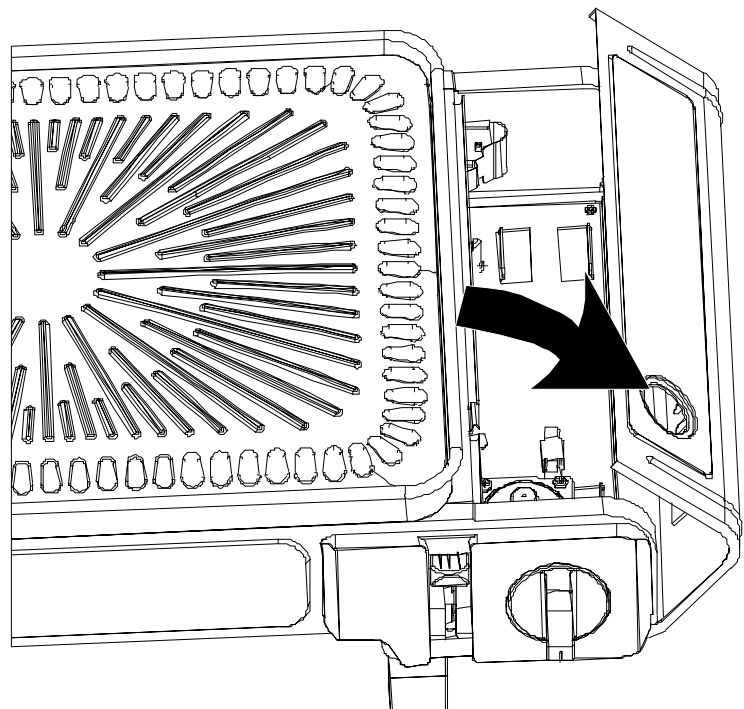
**3**

Flip open the gas cartridge cover (10).

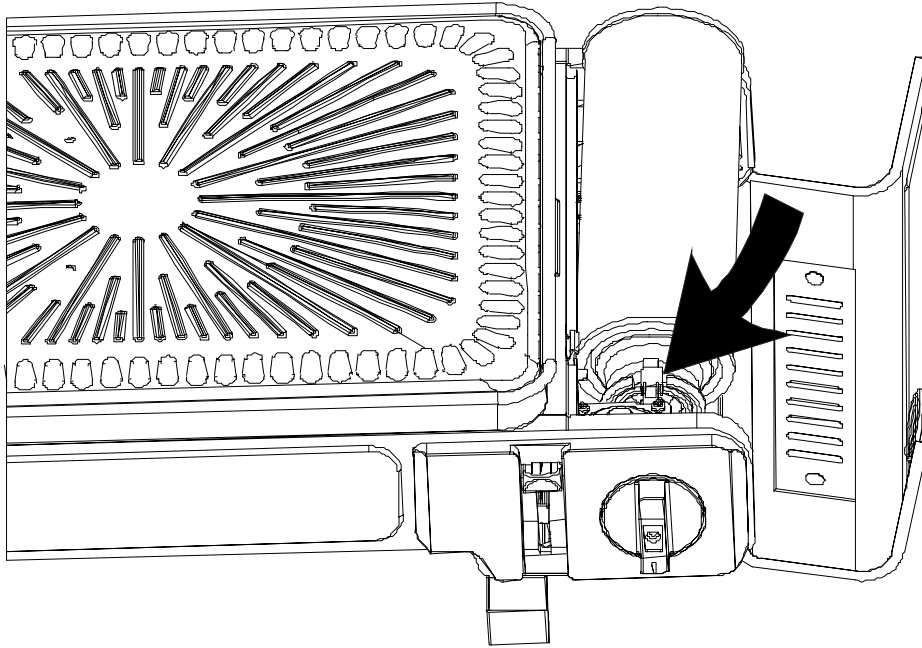
**4**

Locate butane gas cartridge into the cradle. This should be compatible alternative that complies to EN417.

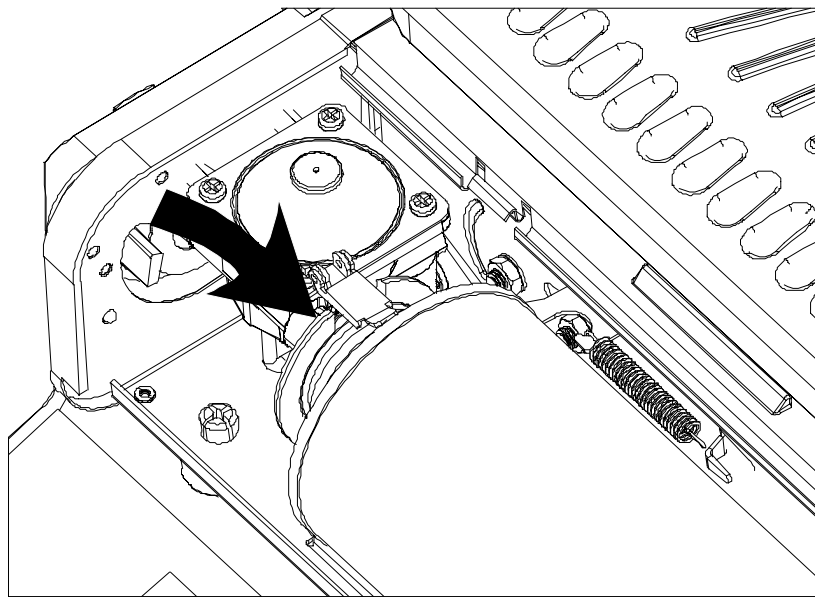
**5**

Ensure the butane gas cartridge seats correctly into seal and the cannister slot lines up with the safety alignment lug (9).

## 6

Push down the cartridge locking lever (7) into the lock position and then close gas cartridge cover (10).

**IMPORTANT**

Check no leaks can be smelt or heard before proceeding. The BBQ is now ready to ignite and use.

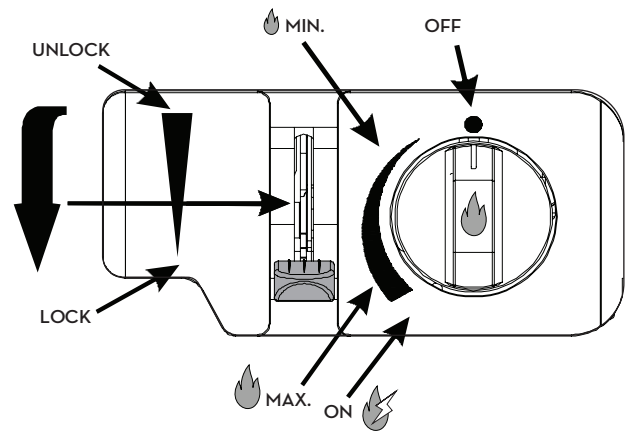

## 7

**Ignition sequence**

Turn the control knob (8) fully anti-clockwise to ignite flame and adjust the control knob to the desired setting.

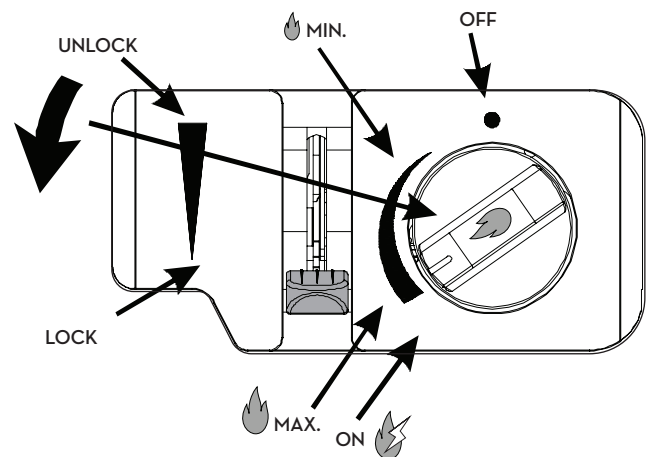
**Turning off the burner.**

Turn control knob (8) fully clockwise to OFF position and move cartridge Locking and release lever to unlock position off. Remove gas cartridge and store in a cool dry place.

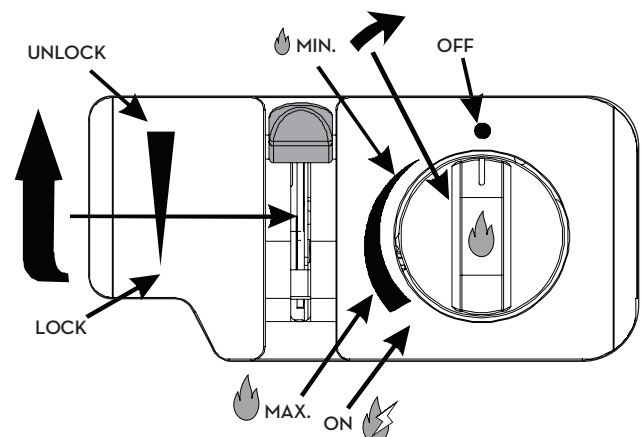

---

**PLEASE NOTE BEFORE IGNITING:**

A small amount of "flaring" may occur when first igniting which is due to gas pressure build-up. Be careful not to lean over the grill when igniting to avoid damage to hair and skin.

As a safety precaution, once the cartridge has been removed, turn the control knob to ignite a couple of times. This will ensure that any gas left in pipe has been used.

**Never attempt to remove canister whilst heater is turned on.**

---

**IMPORTANT NOTES WHEN COOKING:****Emptying grease tray**

Pour about 800ml of water to "grease tray" and put in right position before ignition.

Pay attention to the vaporization of water in the grease tray when in long time use. Supplying suitable water from upper grill approx one hours.

It is important that the grease tray is checked regularly. We recommend it is emptied when approximately two thirds full, and pour water again.

Always empty and clean grease tray when finished using the grill.

**Dispose of oil safely.**

Do not tip oil into any drains or onto land, as this will result in the pollution of rivers or groundwater.

Do not use metal spatulas as these can damage the protective cooking surface.

Avoid leaving grill on when not in use as this can cause unnecessary over heating of the Grill surfaces resulting in reduced efficiency.

---

**IMPORTANT NOTES WHEN CLEANING:**

Only clean the appliance when turned off and cool to touch. Clean the surface of the cooking plates with a damp cloth and wipe dry. Under no circumstances wipe or clean any part of the appliance with an abrasive or a chemical or alcohol based cleaner.



Try to make one of our favorites



## SATÉ PONOROGO

MALAYSIAN MARINATED CHICKEN, BEEF AND SCAMPI  
 SKEWER, WITH HOME-MADE PEANUT SAUCE

4 SERVINGS

### INGREDIENTS

200 g chicken fillet  
 200 g beef  
 200 g scampi  
 1 bunch of coriander

Slice the chicken and beef into suitably sized strips, rinse the scampi, remove intestinal string if still there. Marinade overnight.

### MARINADE INGREDIENTS

1 knife edge of black pepper  
 1/4 lemon grass  
 1 shallot onion  
 2 red chilis with seeds removed  
 1 tbsp. finely shredded, fresh ginger  
 1 tsp. turmeric  
 1 tsp. ground coriander  
 1 tsp. ground caraway  
 1/2 dl soya sauce  
 1/2 dl fish sauce  
 50 g brown sugar  
 2 dl sunflower oil

**Marinade:** This is a really simple marinade. Even though there are lots of ingredients and it may look complicated, the main thing is to find and measure out all the ingredients.

Mix all the ingredients for the marinade in a blender or kitchen machine, making sure everything is well blended.

### PEANUT SAUCE INGREDIENTS

10 g fresh ginger  
 1 chili, with seeds  
 50 g coconut powder  
 1 1/2 dl peanut butter  
 50g brown sugar  
 1 dl fish sauce  
 2 tbsp. tamarind paste  
 1 carton coconut milk (4 dl)  
 1/2 dl soya sauce 300 g peanuts

**Peanut sauce:** The peanut sauce is easy to prepare. Mix all the ingredients except the peanuts in a blender or kitchen machine using a blade in the same way as for the marinade. Pour the sauce into a pan and bring to the boil on low heat while stirring with a ladle. Be careful to avoid letting it burn. Crush the peanuts to a coarse consistency with a mortar or knife or mix quickly in a kitchen machine with a blade that is not too fine. Add to the sauce when brought to the boil.

Once the meat and scampi have marinated for 24 hours, thread them onto a wooden skewer soaked in water. Grill the skewers on the grill, or in a pan just before serving, or roast them a little beforehand and finish off when ready to serve. We recommend the latter if you have a lot of guests. That way, you can avoid standing in the kitchen, and can enjoy their company instead. Sprinkle over the coarsely chopped coriander and serve with the peanut sauce as a dip. A little fresh mango is also recommended.

GET MORE FANTASTIC RECIPES:

[youtube.com/flyingculinaryTV](https://www.youtube.com/flyingculinaryTV)



PROBLEM	POSSIBLE CAUSE	SOLUTION
<b>BURNER WILL NOT LIGHT</b>	Gas can is empty.	Replace gas can.
	Pressure safety lever is in open position.	Push lever to locked position.
	Gas cartridge not located correctly.	Check cartridge is aligned correctly and control lever is in lock position.
	Burner jet blocked	Clean jet with wire brush to remove any dirt or grit.
	Control knob not operating correctly.	Contact your dealer.
	Windy conditions.	Place the BBQ in a less exposed position.
	Low outdoor temperature	Butane gas is not very suitable in temperatures below 10 °C.
<b>MISSING OR UNEVEN FLAMES</b>	Gas can is empty.	Replace gas can.
	Burner jet blocked	Clean jet with wire brush to remove any dirt or grit.
	Windy conditions	Place the BBQ in a less exposed position
	Low outdoor temperature	Butane gas is not very suitable in temperatures below 10 °C.
<b>FLAME GOES OUT DURING USE</b>	Gas can is empty.	Replace gas can.
	Burner is blocked	Clean the burner
	Windy conditions	Place the BBQ in a less exposed position
	Low outdoor temperature	Butane gas is not very suitable in temperatures below 10 °C.



**FETTBRAND SKADAR METALLEN, LACKEN OCH EMALJEN.**

SKADOR PÅ GRILLEN PÅ GRUND AV FETTBRAND TÄCKS INTE AV GARANTIN, EFTERSOM DETTA ORSAKAS AV FELAKTIG ANVÄNDNING.



**NEVER USE WATER TO EXTINGUISH A GREASE FIRE!**

**CLEAN THE BBQ REGULARLY TO AVOID GREASE FIRE.**



# PORTABLE GAS BBQ

## WARRANTY CLAIM

This product is covered by a warranty in accordance with consumer legislation. It has undergone strict quality controls and testing at the factory. If there are any parts missing or the product has been damaged, please contact your dealer or the consumer contact below for help.

In the event of damage to the product, we ask for pictures of the damage and damage to the product's packaging is attached to the complaint.

Faults due to misuse, lack of maintenance or modification of the product will invalidate the warranty. Damaged parts not due to a fault with the product will be invoiced according to our price list + carriage and administration fee.

If new parts are needed or in the event of a warranty claim, please contact your dealer or consumer contact:

## FCC PRODUCTS AS

KJELLER VEST 3, 2007 KJELLER,  
NORWAY



+47 924 78 600

Support opening hours: Mon-Fri 10:00-14:00

✉ support@fccbbq.com

**FCCBBQ.NO**

**FCCBBQ.SE**

**FCCBBQ.COM**

**Always attach your receipt and product serial number when making a warranty claim.**

---

PRODUCED IN CHINA FOR FCC PRODUCTS

We are always looking for ways we can improve our products. Therefore, we reserve the right to change technical specifications at any time. You will always find the latest manual on [WWW.FCCBBQ.COM](http://WWW.FCCBBQ.COM).