

F C C
B B Q

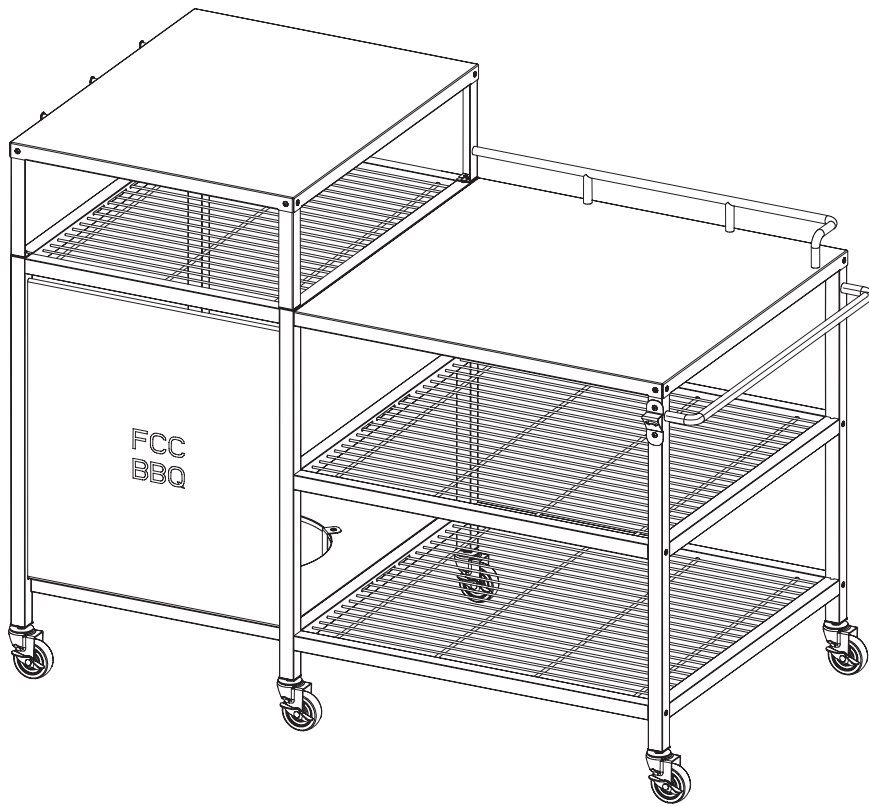

PIZZA STATION

F C C
B B Q
FCC-A-10134

A S S E M B L Y & I N S T R U C T I O N

IMPORTANT, KEEP THE MANUAL FOR FUTURE REFERENCE: READ CAREFULLY.

WHO ARE WE?

The Flying Culinary Circus is the world's first traveling cooking group. In 2005 Trond, Hans-Kristian, Mathias, and Tor, went to New York. A journey that ended up being an adventure of a lifetime. With 65 countries and 300,000 hours of culinary experience in the Chef whites, we have developed, designed, and produced a wide range of grills and accessories that add something new and unique to the grill range in the Nordic region.



Hans-Kristian, Mathias, Trond and Tor.

Something we have always had is great love for grilling and barbeque as a cooking method. Whether we have a garden party, enjoy summer evenings in the park, cater for famous guests on the French Riviera or simply just go on a cabin trip, barbecue and grilling is in the center. It's fantastic flavors, it's tough, it's cool and it's love for the most amazing cooking method in the world! 2024 will be the seventh year for FCC BBQ, and we're very proud and humble for the success and what we as a company have achieved. For all of FCC BBQ products, the common denominator is high quality and functionality at a good price. We want to inspire the world through cooking. Just as our vision: Share the fun of cooking!

F C C
B B Q

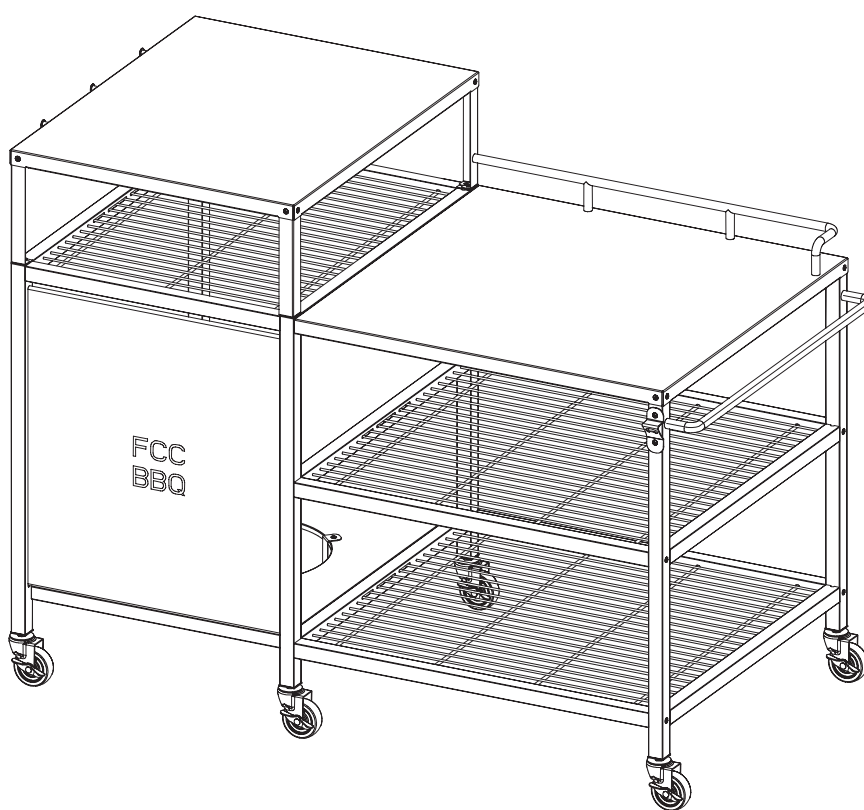

FCC-A-10134

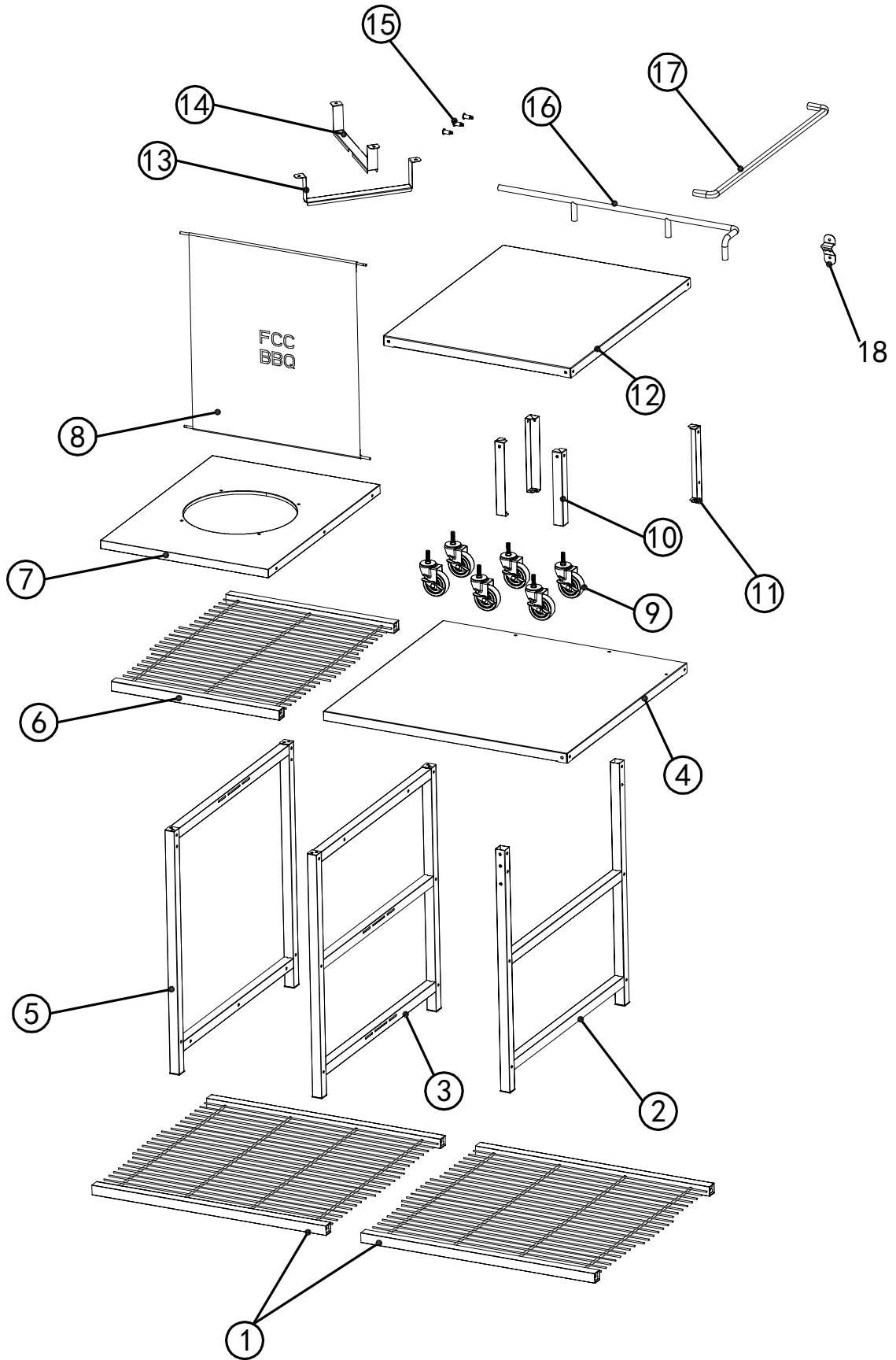

Code	Description	Qty
1	Wire shelf	2
2	Right side panel	1
3	Sender panel	1
4	Table top	1
5	Left leg	1
6	Wire shelf	1
7	Bottom plate with hole for gas cylinder	1
8	Textile front wall	1
9	Wheels with brake	6
10	Leg to table top	3
11	Leg to top shelve with hole	1
12	Table top	1
13	Gas bottle support	1
14	Gas bottle support	1
15	Suspension hooks	3
16	Edge to table top	1
17	Handle	1
18	Bottle opener	1
	FASTENERS	
A	M5-45	14
B	M5-12	20
C	M5-12	18

We recommend assembling the module on a flat surface. Insert all screws first, do not tighten. Tighten all screws when module is fully assembled.

Maximum load/weight:: 130 kg

WARNING!

DO NOT USE ELECTRICAL TOOLS WHEN INSTALLING. TOOLS WITH MACHINE POWER CAN DAMAGE THE COATED SURFACE AND SCREWS WHICH CAN LEAD TO PRODUCT DAMAGE AND RISK OF RUST.

TIP!

Install on a flat surface. If the module is perceived as skewed after installation, loosen all the screws and adjust before tightening.

1

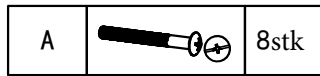

Mount part 1 wire shelf to part 2 right side panel and part 3 center panel with 8 pcs A screws.

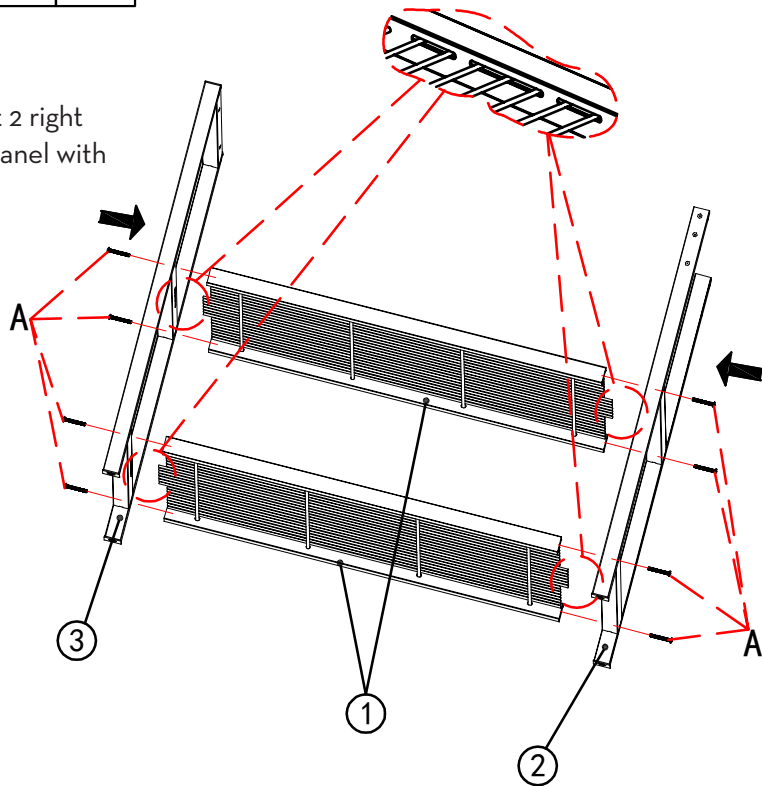

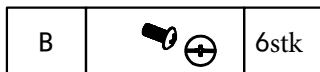

2

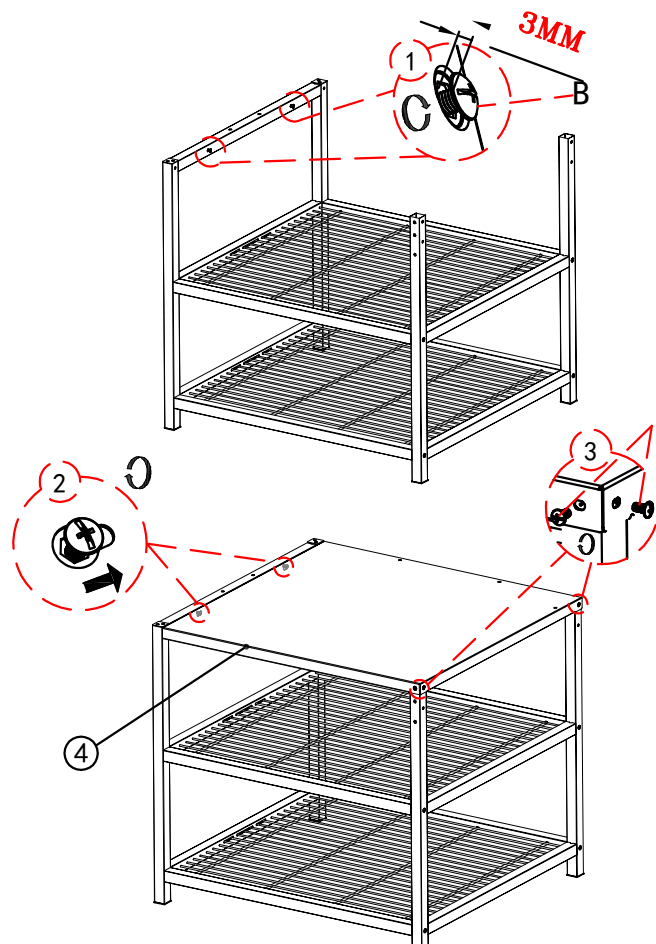

Admission 2 pcs screw B to center legs. Three top-plate part 4 on the screws and screw firmly with 4pcs B screws. Tighten the first two screws when the top-plate is mounted. Tip all the screws before tightening.



3

B		3stk
A		2stk

Install wire shelf part 6 and bottom plate part 7 to part 5 left side rail with 3 pcs screw B and 2 pcs screw A.

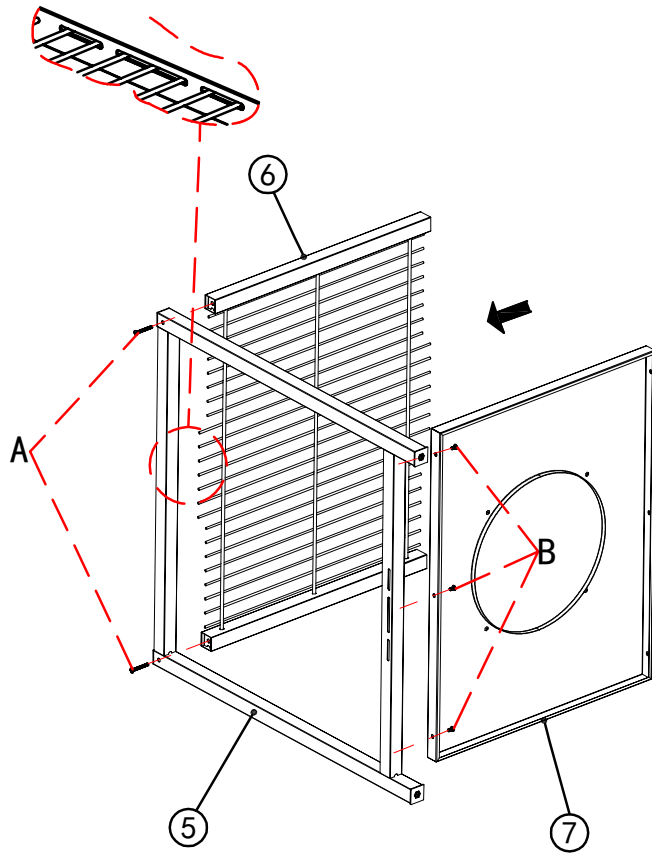

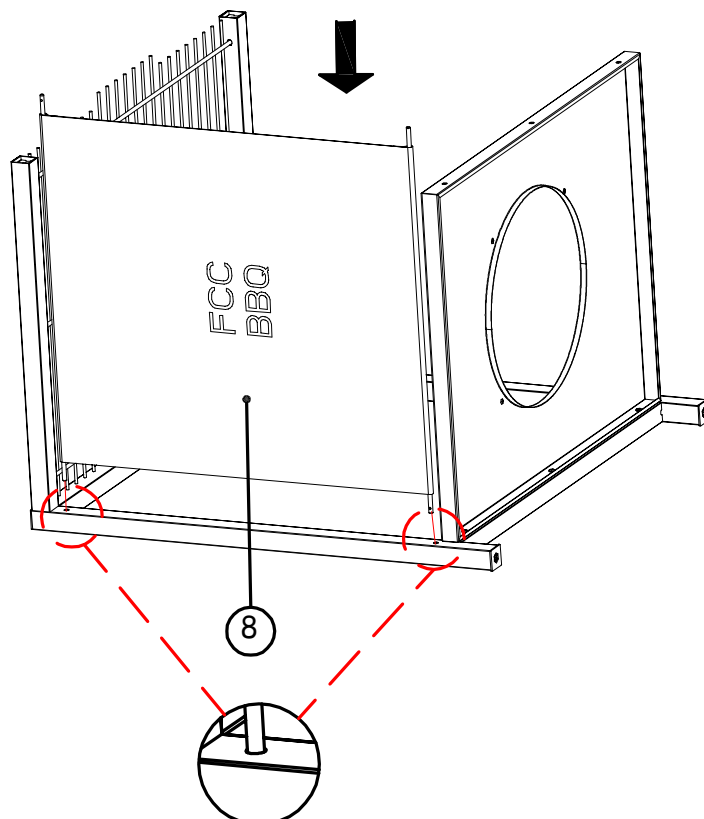

4

Put on the front wall in textile part 8.



5

B		3stk
A		2stk

Assemble the parts together with 3 pieces B screws and 2 pcs A screws.

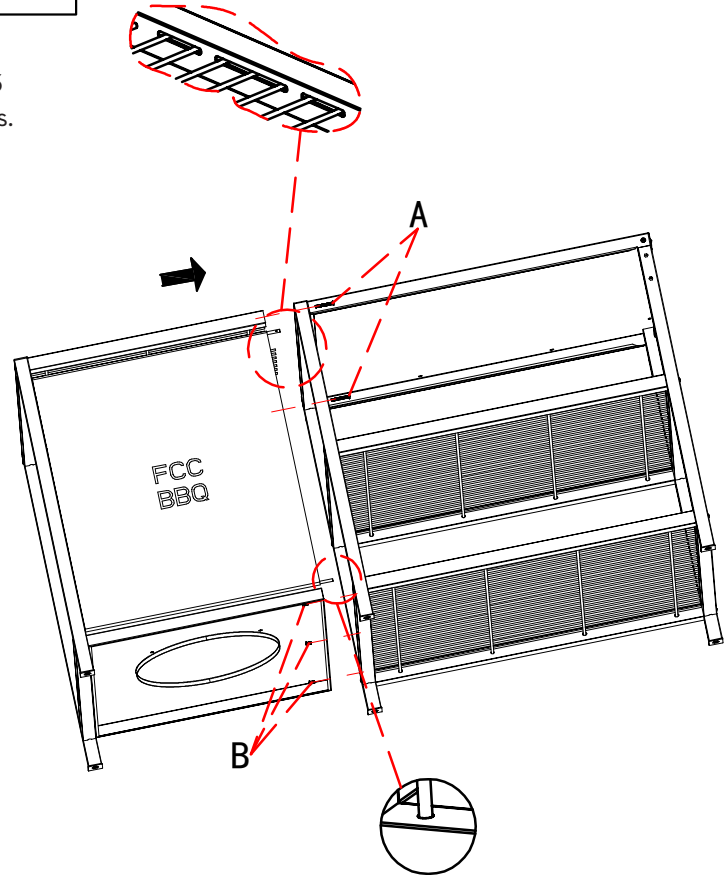

6

Screw on Part 9 wheels with brake.

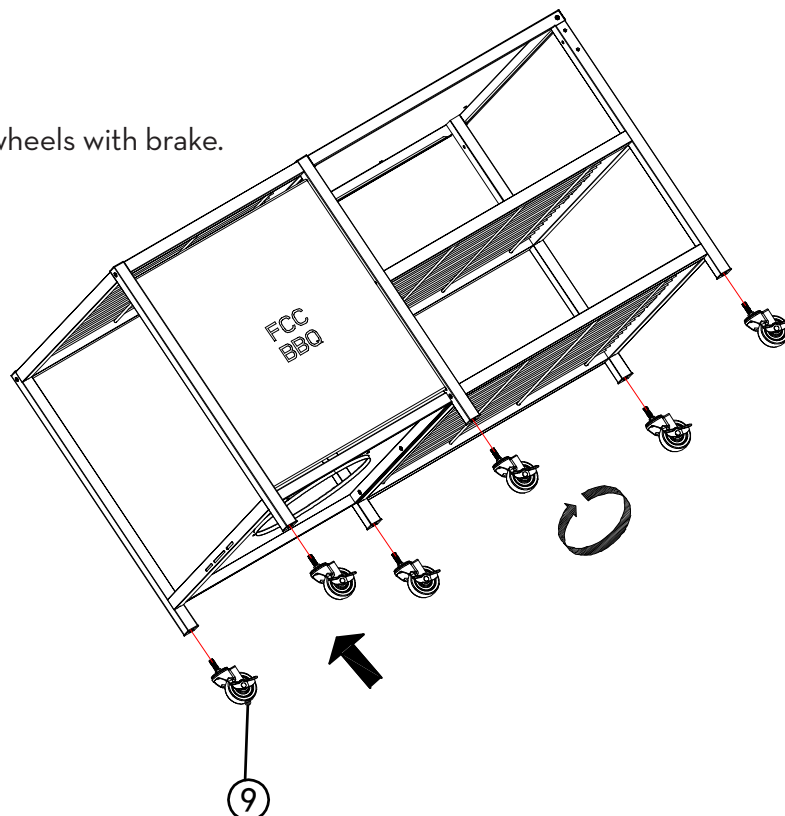

7

B		8stk
---	---	------

Mount 3 pieces of part 10 legs to the top plate. Mount part 11 legs with holes to the top plate on the right side at the back with a total of 8 pcs screws B.

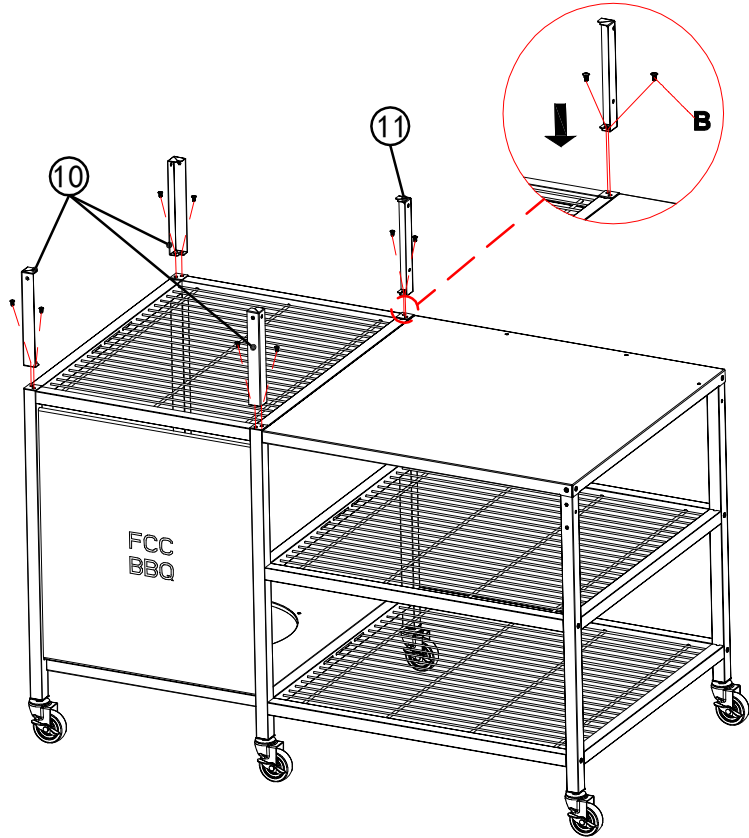

8

C		8stk
---	---	------

Mount top-plate part 12 with 8pcs C screws. Tip: Admission all screws before tightening.

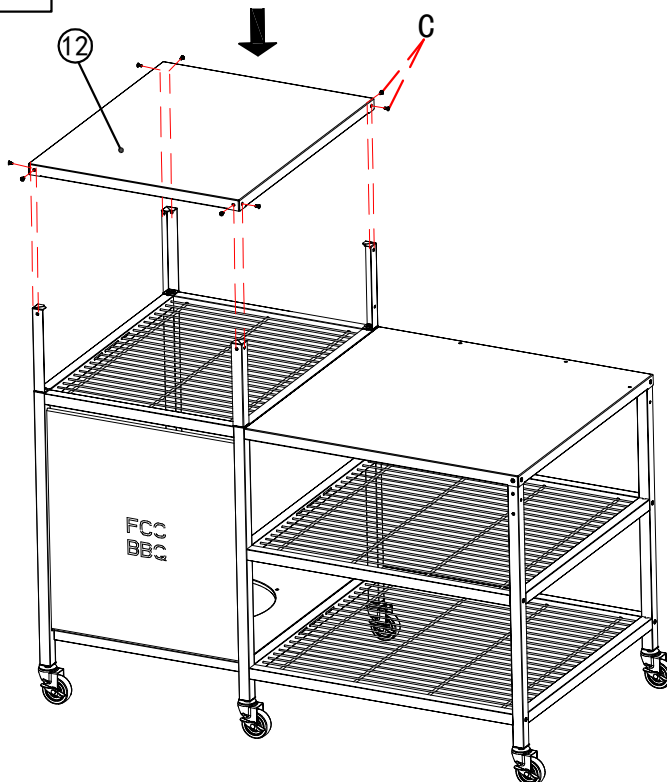

9

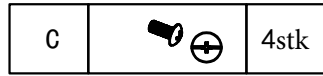

Install 3 suspension hooks, part 15. Then mount holder to gas cylinder with part 13 and 14 with 4pcs C screws.

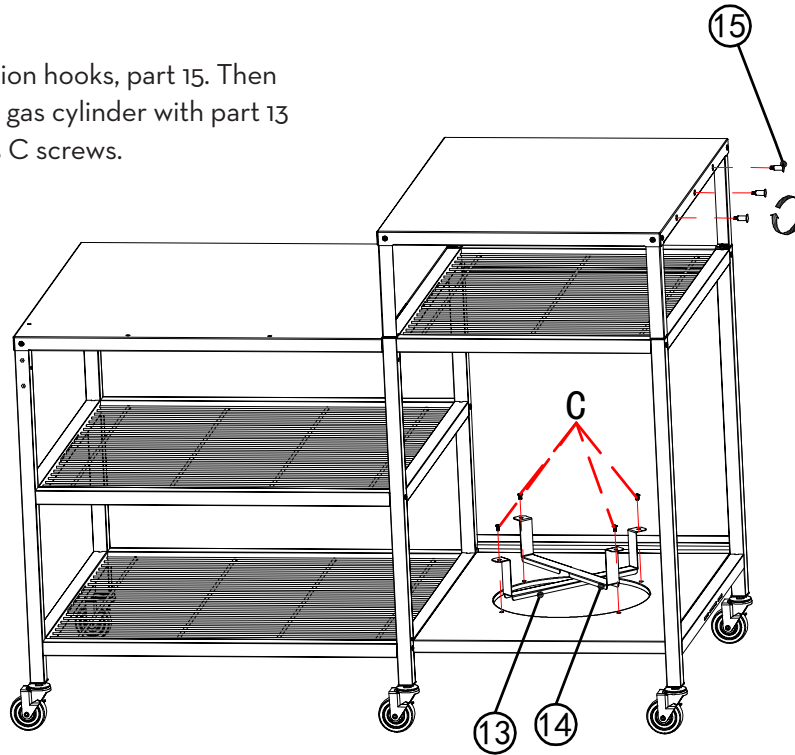

10



Mount part 10 edge to top plate with 4pcs C screws. TIP: Thread the screws before tightening.

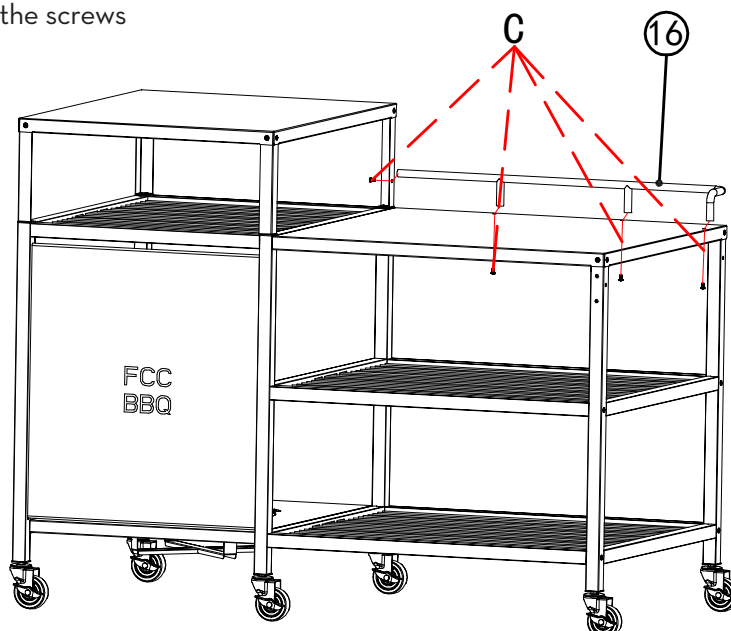

11

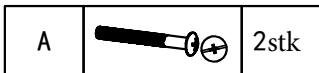

Install part 17 handles with 2 pcs A screws.

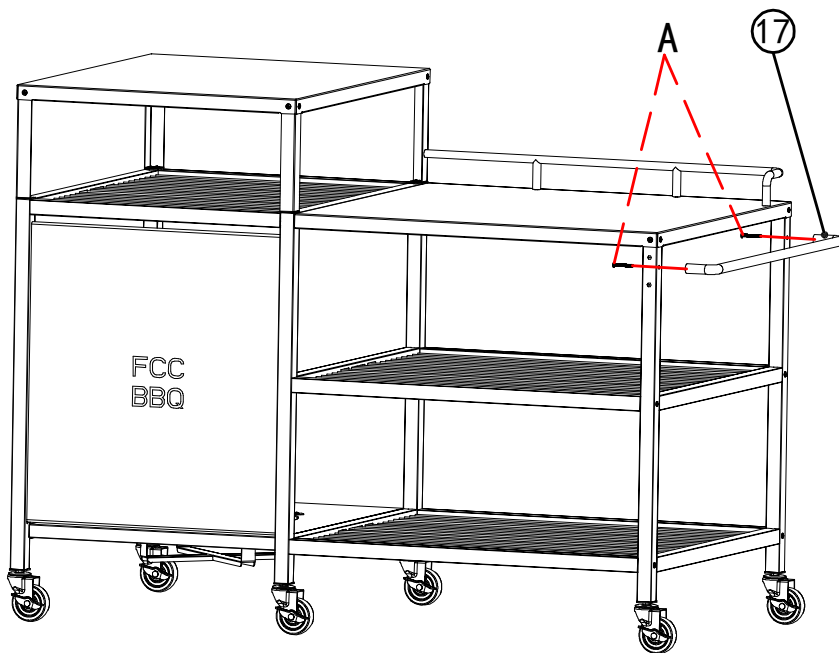

12



Install part 18 bottle opener with 2 pcs C screws.

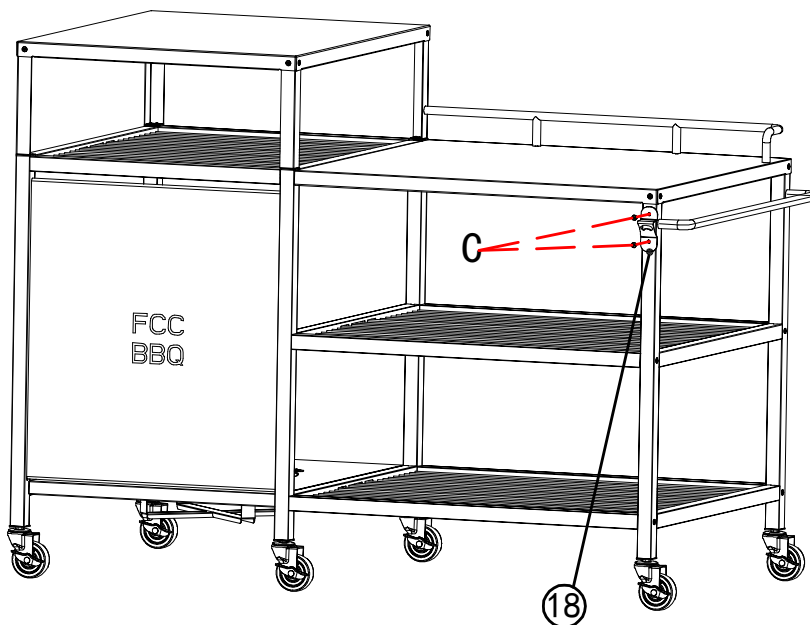

WARNINGS AND SAFETY INFORMATION

- If the furniture is to be stored outdoors all year, then you must ensure that water is drained from the furniture and that it is not left standing with water in the frame. This can cause frost damage and will not be covered by warranty.
- THIS PRODUCT IS DESIGNED FOR USE IN DOMESTIC HOUSEHOLDS AND IS NOT INTENDED FOR COMMERCIAL USE IN RESTAURANTS OR SIMILAR VENUES
- Covers must not be applied before the pizza station is completely cool and dry. Moisture on the inside of covers may cause large formations of surface rust and damage to those parts that are in coated steel and stainless steel.
- VARNISHED PARTS AND FABRIC WILL BE ABLE TO BLEACH UNDER THE INFLUENCE OF SUNLIGHT.
- Keep children and others who require supervision at a safe distance away to prevent them from climbing on the furniture. This may entail a risk of injury. Children must be supervised by adults when using the pizza station.
- Inserting screws wrongly, torquing with excessive force, or using electrical tools may damage the threading. The aluminum frames can bend if you tighten the screws too hard. Damage as such will not be covered by the warranty.
- Do not use electrical tools to assemble the furniture. Tools with excessive force may damage the surface coating of screws, damage enamel/painted parts of the grill, and loosen pre-fitted nuts.
- The surface of the furniture may become very hot in direct sunlight. Please be aware of this and avoid use in high temperatures, as this may cause injury.
- Check for the presence of any damage before assembly. Please contact support@fccbbq.no for any inquiries.
- The painted surface of the furniture can be worn/scratched during use. This must be fixed to prevent rust from forming in damaged surface areas.
- The painted surface of the furniture may be affected by sunlight. This does not affect the properties of the furniture and is not covered by warranty. To prevent this, use a cover to protect.
- Note! The furniture may have sharp edges. We have done our best to remove sharp edges during production, but we recommend to exercise caution when handling the product.

MAINTENANCE

- If the pizza station is located in coastal areas, we recommend that you treat the pizza station more often.
- Wipe off food residues, grease and other things after use. If this is left behind, it can lead to rust formation.

- **COATED AND STAINLESS STEEL PARTS**

Inadequate maintenance/cleaning may cause coated or stainless steel parts of the pizza station to begin rusting. To maintain the great appearance and surface of the pizza station, it must be regularly cleaned using gentle cleaning agents and warm water to remove salt, grease and other residue that can harm the surface. After washing, dry the surface off with a soft cloth.

Coated surfaces must be treated with a polishing agent (e.g., car polish) and stainless steel parts must be treated with a thin layer of acid-free oil one to two times per year. If the product is kept in coastal areas, we recommend performing treatment more often to prevent salt carried by wind/rain from causing the surface of the metal to rust.

Surface rust can be removed by cleaning the surface and applying a polishing agent. Please note that the warranty only covers rust perforation. putting a cover over it.

Coated surfaces must be treated with a polishing agent (e.g., car polish) and stainless steel parts must be treated with a thin layer of acid-free oil one to two times per year. For barbecues kept in coastal areas, we recommend performing treatment more often to prevent salt carried by wind/rain from causing the surface of the metal to rust.

Surface rust can be removed by cleaning the surface and applying a polishing agent. Please note that the warranty only covers rust perforation.

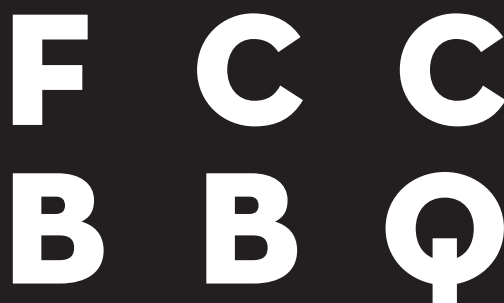

WARRANTY CLAIM

This product is covered by a warranty in accordance with consumer legislation. It has undergone strict quality controls and testing at the factory. If there are any parts missing or the product has been damaged, please contact your dealer or the consumer contact below for help.

In the event of damage to the product, we ask for pictures of the damage and damage to the product's packaging is attached to the complaint.

Faults due to misuse, lack of maintenance or modification of the product will invalidate the warranty. Damaged parts not due to a fault with the product will be invoiced according to our price list + carriage and administration fee.

If new parts are needed or in the event of a warranty claim, please contact your dealer or consumer contact:

FCC PRODUCTS AS

KJELLER VEST 3, 2007 KJELLER,
NORWAY



+47 924 78 600

Man-Fre 10:00-14:00

✉ support@fccbbq.com

FCCBBQ.NO

FCCBBQ.SE

FCCBBQ.COM

Always attach your receipt when making a warranty claim.

PRODUCED IN CHINA FOR FCC PRODUCTS

We are always looking for ways we can improve our products. Therefore, we reserve the right to change technical specifications at any time. You will always find the latest manual on WWW.FCCBBQ.COM.