

F C C  
B B Q

CHEF'S TABLE  
T O P



**FCC-GG-230100-20**

**USER MANUAL**

Assembly, maintenance and safety

**! OUTDOOR USE ONLY**

READ THE MANUAL, FOLLOW THE ASSEMBLY INSTRUCTIONS STEP BY STEP. GET TO KNOW YOUR BARBECUE AND THE SAFETY INSTRUCTIONS BEFORE USING THE APPLIANCE!

SCAN QR CODE AND REGISTER BARBECUE FOR EXTENDED WARRANTY



SCAN QR CODE FOR BARBECUE ASSEMBLY VIDEO



### WHO ARE WE?

The Flying Culinary Circus is the world's first traveling cooking group. In 2005 Trond, Hans-Kristian, Mathias, and Tor, went to New York. A journey that ended up being an adventure of a lifetime. With 65 countries and 300,000 hours of culinary experience in the Chef whites, we have developed, designed, and produced a wide range of grills and accessories that add something new and unique to the grill range in the Nordic region.

Something we have always had is great love for grilling and barbeque as a cooking method. Whether we have a garden party, enjoy summer evenings in the park, cater for famous guests on the French Riviera or simply just go on a cabin trip, barbecue and grilling is in the center. It's fantastic flavors, it's tough, it's cool and it's love for the most amazing cooking method in the world!

2023 will be the sixth year for FCC BBQ, and we're very proud and humble for the success and what we as a company have achieved. For all of FCC BBQ products, the common denominator is high quality and functionality at a good price. We want to inspire the world through cooking. Just as our vision:

Share the fun of cooking!

# FCC BBQ

*by The Flying Culinary Circus*



Hans-Kristian, Mathias, Trond and Tor

---

The story of FCC.....	2
Warnings .....	5
Technical Data .....	6
Read before assembly .....	7
Parts List .....	8
Exploded Drawing.....	9
Assembly Instructions .....	10
Regulator and Hose - Connecting the gas .....	13
Check for leaks before using the barbecue .....	14
Last Check .....	16
Lighting Instructions .....	17
Maintenance .....	18
Advice, tips and safety .....	20
Troubleshooting .....	21
Consumer Contact .....	22

- ACCESSIBLE PARTS OF THE BARBECUE BECOME VERY HOT DURING USE. KEEP CHILDREN AND OTHERS WHO NEED SUPERVISION AT A SAFE DISTANCE. 
- THE BARBECUE IS INTENDED FOR OUTDOOR USE ONLY IN WELL-VENTILATED AREAS.
- LEAK TESTS (SEE PAGE 14) MUST ALWAYS BE CARRIED OUT BEFORE THE BARBECUE IS USED AND WHEN REPLACING THE GAS CYLINDER. ALSO PERFORM A LEAK TEST IF THE PRODUCT HAS NOT BEEN IN USE FOR A LONG TIME AND IN ADVANCE OF A NEW BARBECUE SEASON. ALWAYS CHECK THE GAS HOSE FOR DAMAGE AND CRACKS BEFORE USING THE BARBECUE.
- NEVER GRILL IN CLOSED ROOMS OR UNDER ROOFS, AS THIS MAY LEAD TO A LACK OF OXYGEN.
- FAILURE TO FOLLOW THE INSTRUCTIONS PROVIDED CAN IMPLY A RISK OF SERIOUS INJURY TO PERSONNEL AND FIXED INSTALLATIONS.
- REBUILDING/MODIFYING THE BARBECUE CAN CAUSE DANGER AND WILL INVALIDATE THE WARRANTY.
- ALWAYS SUPERVISE THE BARBECUE DURING USE AND KEEP SUITABLE EXTINGUISHING EQUIPMENT WITHIN REACH. THE BARBECUE SHOULD NOT BE OPERATED BY INTOXICATED PERSONS.
- THE BARBECUE MUST NOT BE USED IN PLACES THAT ARE BELOW NORMAL GROUND LEVEL. GAS CAN ACCUMULATE AND REPRESENT A DANGER OF EXPLOSION. GAS ACCUMULATION CAN ALSO CAUSE OXYGEN DEFICIENCY.
- THE BARBECUE MUST BE CLEANED REGULARLY AND THOROUGHLY TO PREVENT UNCONTROLLED GREASE FIRE. READ MORE ABOUT GREASE FIRE ON PAGE 18.
- ALSO READ PAGE 20 FOR MORE ADVICE AND TIPS ON GRILLING AND SAFETY.

#### **FIRST TIME USE - GRILL BURN-OFF**

BEFORE USING THE BARBECUE FOR THE FIRST TIME, IT IS IMPORTANT TO COMPLETE A BURN-OFF. FIRE UP THE BARBECUE AND OPERATE FOR A MINIMUM OF 15 MINUTES ON MAX TEMPERATURE TO BURN-OFF THE UNIT. THIS WILL "HEAT CLEAN" THE INTERNAL COMPONENTS, DISSIPATE ODORS AND RID IT OF ANY FOREIGN MATTER.

**Total Heat input:** 4.6kW (butane) 4.2kW (propane)

**Gas consumption:** 335 gram/hour

**Gas cylinder (not included):** Use standard cylinder approved for use in the Nordic Region. Even though butane and propane gas can be used, we recommend propane for use in the Nordic Region. Approved hoses and regulators are available from most outlets selling gas equipment.

**NB!** Gas hoses used for this product must not exceed 120 cm in length.

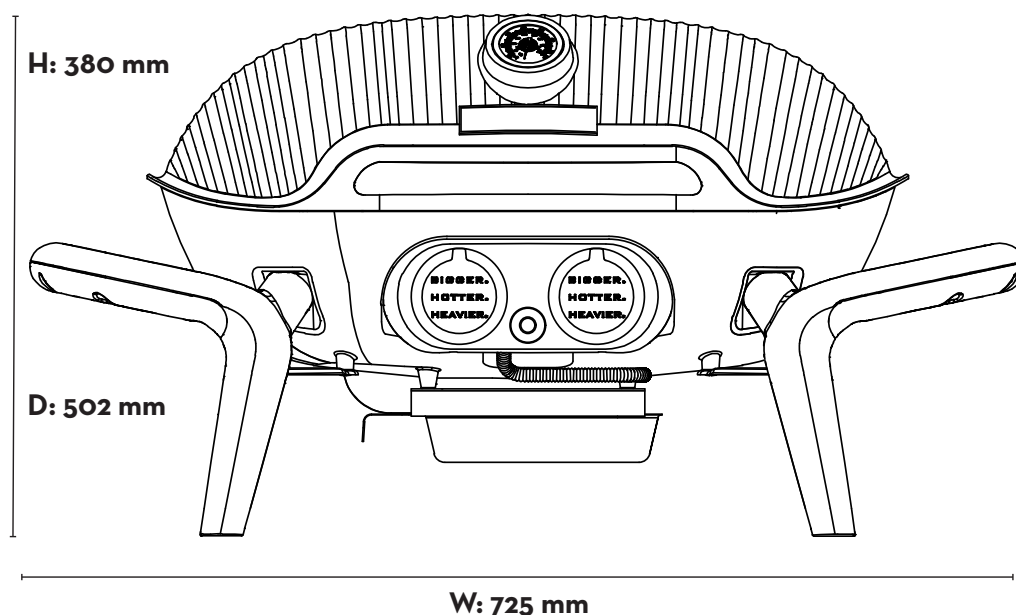

USE ONLY GAS TYPE AND GAS CATEGORY ENTERED IN THIS MANUAL.

DESTINATION OF COUNTRIES TO USE	VALVE SIZE	GAS TYPE	GAS CATEGORY
LU, NL, DK, FI, SE, CY, CZ, EE, LT, LV, MT, SK, SI, BG, IS, NO, TR, HR, RO, IT, HU	Ø 0.75 mm Main Burner	G30(Butane G31 Propane) and their mixtures	I3B/P(30)

CE 1336-22

The product is manufactured in accordance with European Gas Appliances Regulation (EU) 2016/426

**FOLLOW THESE INSTRUCTIONS CAREFULLY TO AVOID SERIOUS PERSON INJURY OR DAMAGE TO YOUR BARBECUE.**

Make sure that all parts and screws are included by comparing the parts list with the contents of the box. Also check that everything is undamaged before assembling the product.

**If the barbecue is damaged during transport, do not assemble the barbecue before contacting your dealer or [support@fccbbq.com](mailto:support@fccbbq.com).**

Transport damage to parts, varnish or enamel must be reported to the dealer or FCC BBQ before mounting and using the barbecue. If damage is reported after, there is a possibility that damage may have occurred during assembly. This will not be considered as transport damage.

**Please note that some parts may be located in the Styrofoam to protect the part during transport. If parts are missing, first check the packaging carefully. Remove all remnants of packaging material and any plastic foil from the barbecue before using the barbecue.**



- **FOLLOW THE ORDER IN THIS MANUAL TO AVOID INCORRECT ASSEMBLY. PARTS OF THE ASSEMBLY WILL REQUIRE HEAVY LIFTING WHICH SHOULD BE PERFORMED BY TWO PEOPLE TOGETHER, TO AVOID PERSONAL INJURY AND DAMAGE TO THE BARBECUE. SOME METAL PARTS MAY BE SHARP, WEAR PROTECTIVE GLOVES.**
- **POWER TOOLS SHOULD NOT BE USED TO ASSEMBLE THE BARBECUE. TOOLS WITH TOO MUCH FORCE CAN DAMAGE THE SURFACE TREATMENT ON SCREWS, DAMAGE ENAMELLED/LACQUERED PARTS OF THE BARBECUE, AS WELL AS LOOSEN PRE-ASSEMBLED NUTS.**
- **IF THE PRODUCT'S VARNISH OR ENAMEL IS DAMAGED DURING ASSEMBLY, WE RECOMMEND THAT THE DAMAGE BE TREATED IMMEDIATELY TO AVOID LATER RUST DAMAGE. SUITABLE HEAT-RESISTANT VARNISH CAN BE ORDERED FROM [SUPPORT@FCCBBQ.COM](mailto:SUPPORT@FCCBBQ.COM).**

A screwdriver (not provided)  
is necessary when assembling the barbecue.

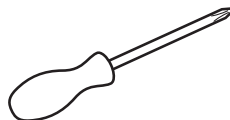

CODE	DESCRIPTION	QTY
1	GRILL BODY	1
2	COOKING GRID	1
3	LID GREASE TRAY	1
4	SUPPORTING LEGS	1
5	LEG BRACE - A	2
6	LEG BRACE - B	2
7	KNOB	2
A	m6X25MM SCREW	4
B	m6X20MM SCREW	4
C	m6X10MM SCREW	4



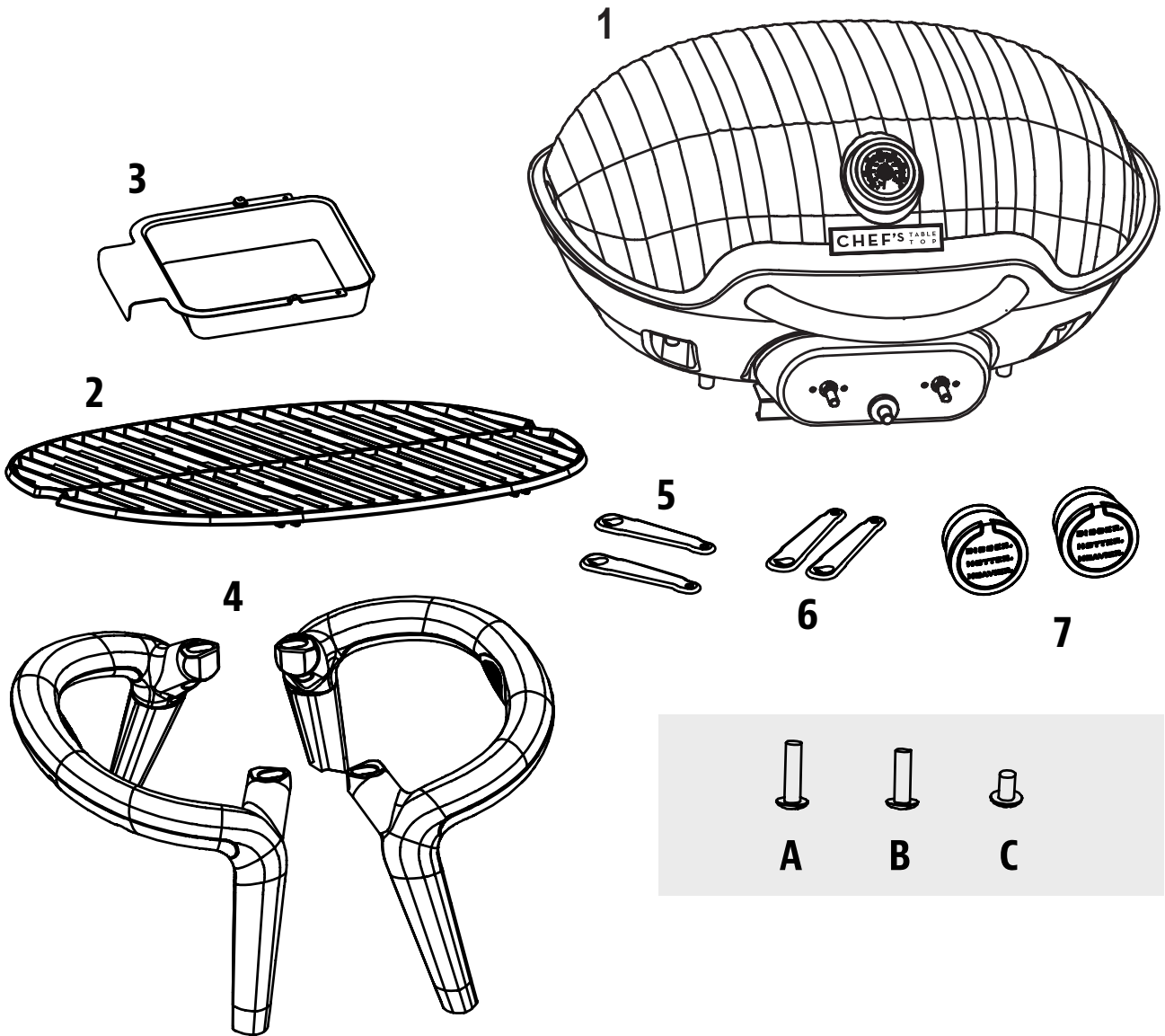

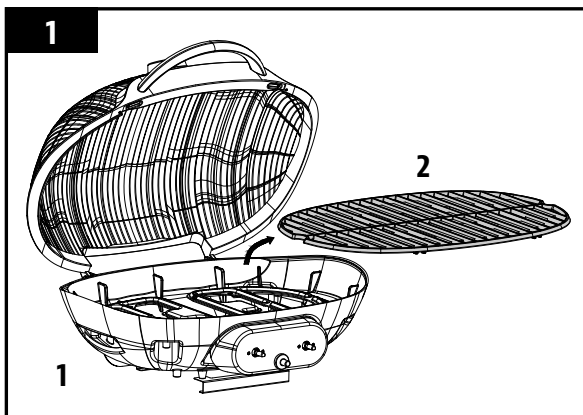

## 1

**Remove the Cooking Grid**

This will prevent it from moving around while completing the assembly.

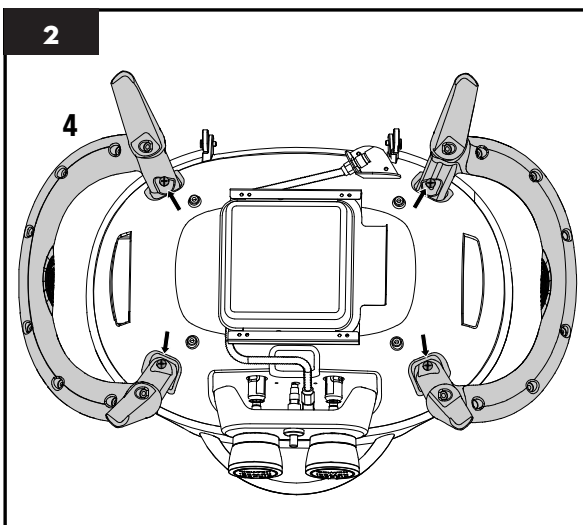

## 2

**Mounting the Legs to the grill body**

Place a piece of cardboard (e.g the grill carton) on the floor to prevent scratching the unit and parts during assembly. Turn the grill body over onto its lid to view the underside of the grill body.

Align one of the Support Legs to the holes on the Grill Body. Use two, m6x25mm screws, to attach the Support Leg. Repeat installation for the opposite leg.

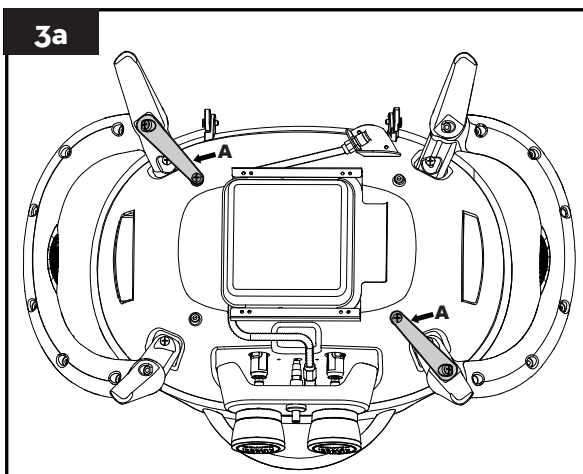

## 3

**Installing Leg Braces**

Secure Leg Brace - A to opposite corners with 2 pcs m6x10mm screws to the body and 2 m6x20mm screws attached to the legs, shown in 3A illustration. Repeat installation for the opposite corners with Leg Brace - B, illustration 3B.

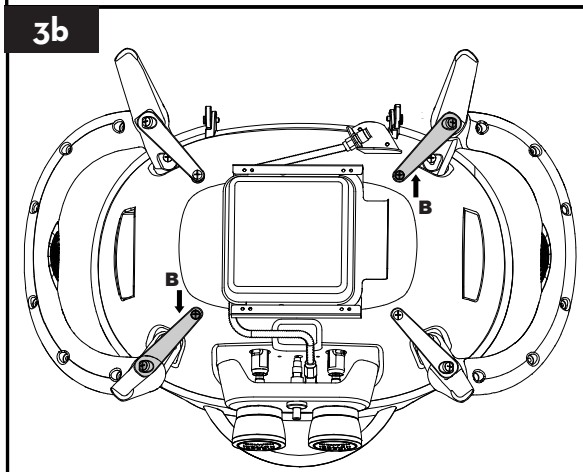

# 4

## Installing the Knobs

Insert the knobs onto the pins of the control panel.

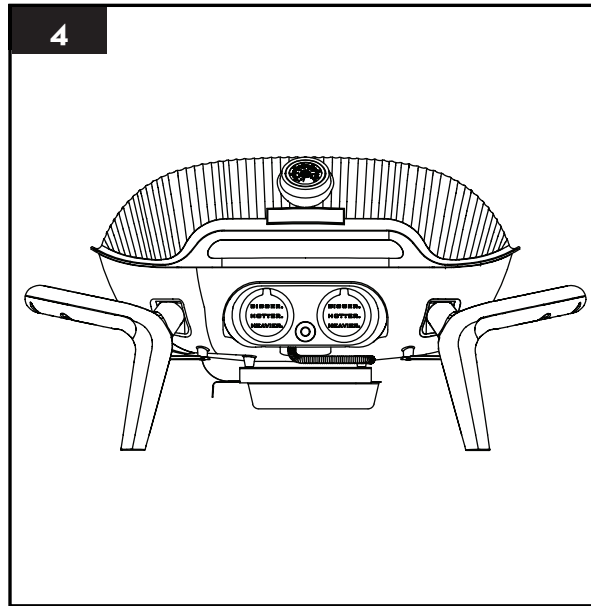

# 5

## Insert the Grease Tray

Slide the Grease Tray (3) between the drip pan brackets as shown in the illustration.

**NOTE: You will hear a click when the Grease Tray is completely inserted.**

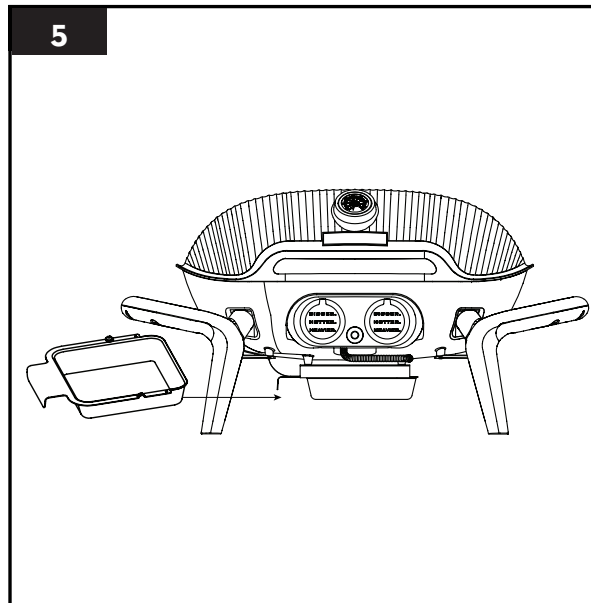

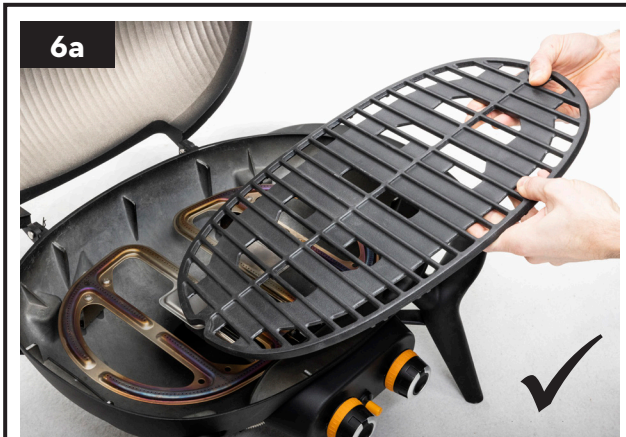

## 6

### Installing the Cooking Grid

Place the Cooking Grid inside the Grill Body, shown in image 6A. **Make sure to place the cooking grid with the correct side facing up.**

**6B:** Image shows the cooking grid inserted **INCORRECTLY**.

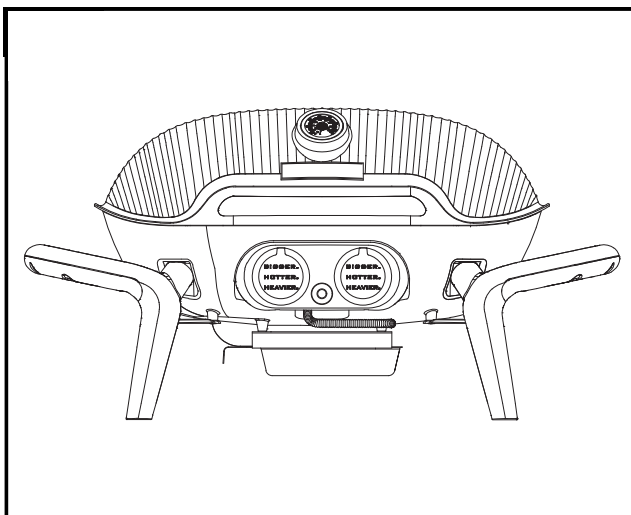

**The unit is now completely assembled.**

**FOLLOW THESE INSTRUCTIONS CAREFULLY TO AVOID SERIOUS DAMAGE TO YOUR BARBECUE AND CAUSE PERSONAL INJURY.**

### HOSE

- Connect the gas hose to the gas inlet on the barbecue. Tighten well.
- Install the regulator and hose. Follow the installation instructions that came with the controller set.
- Do not use sealing tape, glue or liquid on the connection.
- Gas hoses used for this product must not be longer than 120 cm.
- Check the gas hose regularly for cracks, damage and rot. **Never use a damaged gas hose.**

### REGULATOR

- Check that all controls on the control panel are in the OFF position before connecting the regulator to the gas cylinder.
- Connect the regulator to the gas cylinder according to your regulator and the cylinder dealer's instructions.
- We recommend propane gas for use in the Nordic countries, but butane can also be used. Butane is poorly suited for low temperatures.
- Check that the regulator is not damaged.
- Check that the gas cylinder is on a firm, level surface and is lower than the gas inlet on the barbecue.
- Use an approved gas cylinder that fits the regulator. Cylinders of 10 kg or more are recommended.

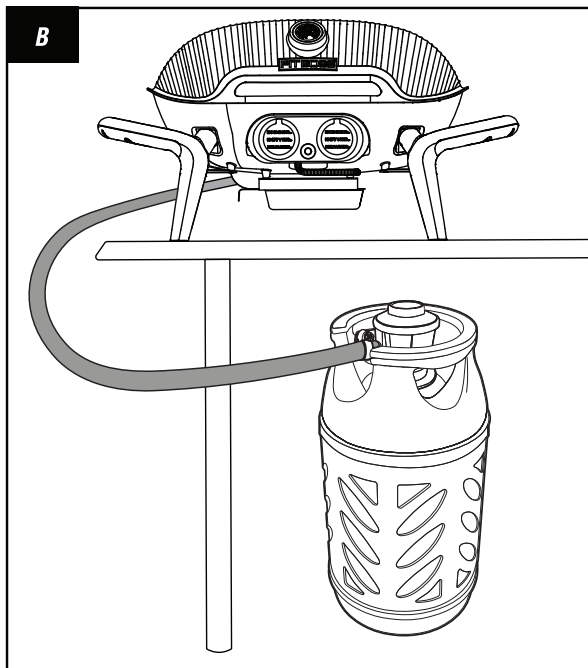
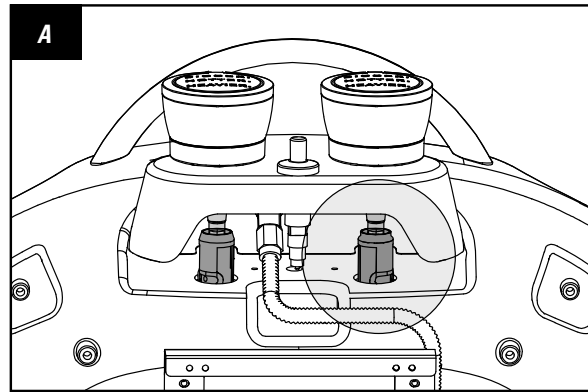

**BEFORE USING THE BARBECUE, A LEAK TEST MUST BE CARRIED OUT!**

**NEVER CHECK FOR LEAKS BY USING AN OPEN FLAME! USE A LEAK SPRAY  
OR ALTERNATIVELY A SOAPY WATER MIXTURE  
(TWO PARTS DISHWASHING SOAP AND ONE PART WATER).**

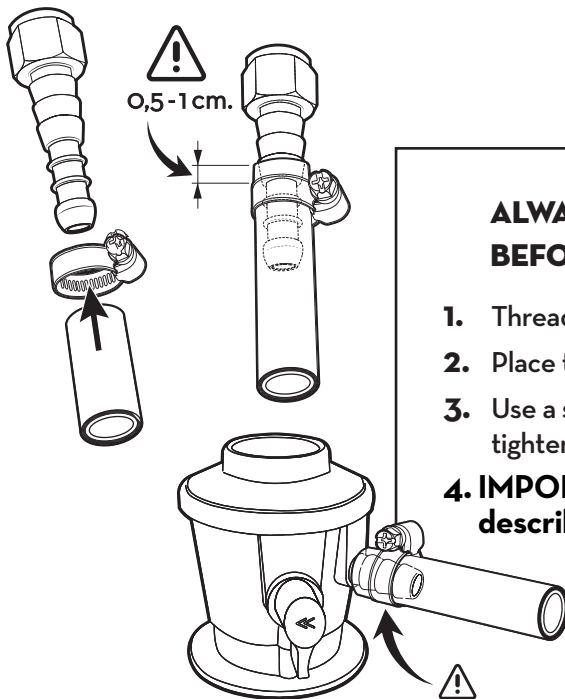

**ALWAYS PERFORM A LEAK TEST  
BEFORE USING THE BARBECUE!**



1. Thread the hose all the way into the gas nipple.
2. Place the hose clamp 0.5 - 1 cm from the end of the hose.
3. Use a socket wrench (size 7), wrench (size 7) or screwdriver to tighten the hose clamp and tighten well.
4. **IMPORTANT! A gas leak test must be performed as described on next page before using the barbecue.**

If the hose is too tight to thread onto the gas nipple, use soap at the tip of the hose. Never use flammable liquids. Alternatively, dip the tip of the hose in boiling water, and the hose will expand.

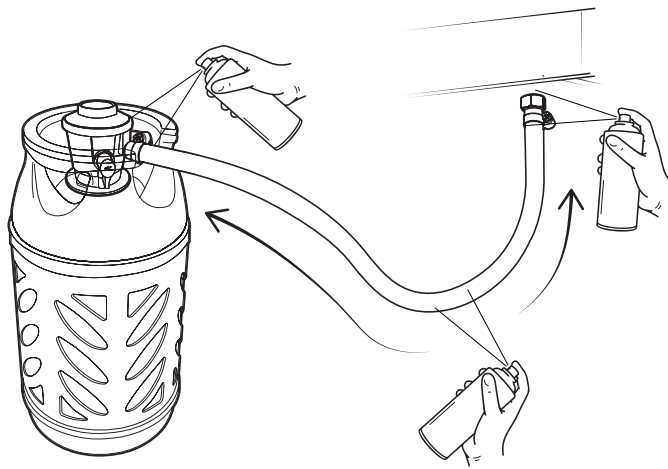

Leak spray

### GAS LEAK TEST

1. Extinguish all live flames, heat sources and cigarettes in the area where the leak test is to be performed.
2. Turn all controls on the barbecue to the OFF position.
3. Set the regulator to the OFF position and connect it to the gas cylinder.
4. Spray the leaking spray (or brush the soap mixture) on all joints and connections on the gas cylinder, regulator, the entire hose and all valves on the barbecue.
5. Open the gas supply on the regulator and carefully check for bubbles in any of the places where the spray mixture is applied.
6. **IF BUBBLES OCCUR, CLOSE THE GAS SUPPLY AND TIGHTEN ALL CONNECTIONS/ JOINTS. THEN DO A NEW TEST.**

**! THE BARBECUE MUST NOT BE USED UNTIL YOU ARE SURE THERE ARE NO LEAKS. GAS LEAK CAN CAUSE UNCONTROLLED FIRE WHICH MAY INJURY PERSONS, FIXED INSTALLATIONS AND YOUR BARBECUE.**

7. If detected leakage cannot be rectified, do not attempt to cure leakage but consult your dealer or FCC BBQ Products support at [support@fccbbq.com](mailto:support@fccbbq.com) for help in solving the problem.



- LEAK TEST MUST BE DONE REGULARLY AND EVERY TIME THE GAS CYLINDER, REGULATOR OR HOSE IS REPLACED.
- ALSO TEST BEFORE NEW GRILL SEASON AND IF THE BARBECUE HAS NOT BEEN USED FOR A WHILE.
- WE RECOMMEND TO PERFORM A GAS LEAK TEST AT LEAST TWICE A SEASON, REGARDLESS OF WHETHER YOU HAVE CHANGED THE GAS BOTTLE OR NOT.

**PLACEMENT OF THE TABLE TOP BARBECUE**

- Ensure that the barbecue is placed at least 150 cm in all directions from house walls, trees, plants and other flammable materials or liquids when in use.
- Do not place the barbecue under a roof or overhang.
- The barbecue must be placed on a higher level than the gas cylinder (e.g. on a table).
- Make sure that the barbecue is placed in a well-ventilated place to avoid carbon monoxide poisoning.
- The barbecue must not be used below normal ground level, as this can lead to an explosion hazard and a risk of lack of oxygen.

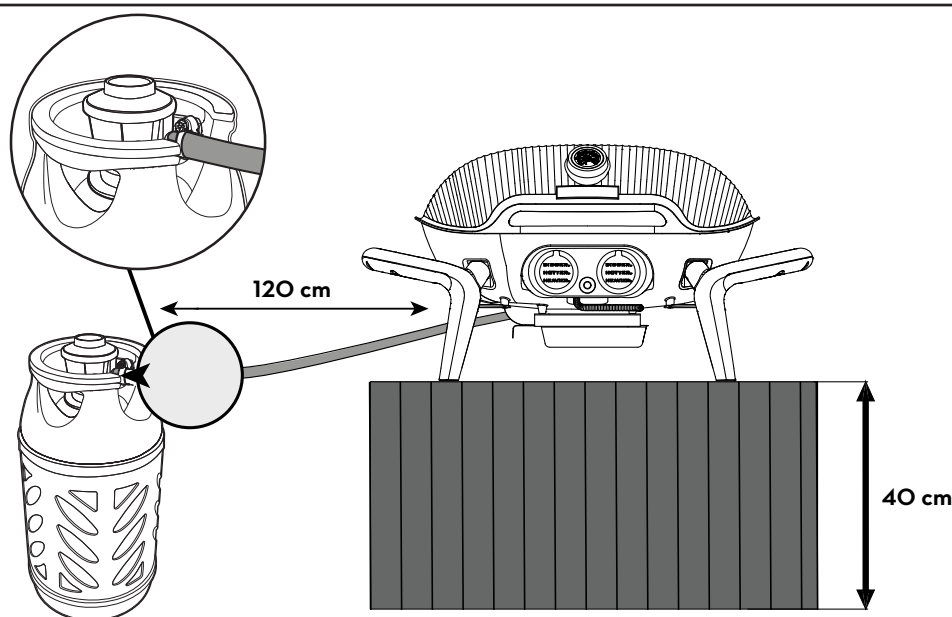
**FIRST USE - GRILL BURN-OFF**

BEFORE USING YOUR GRILL FOR THE FIRST TIME WITH FOOD, IT IS IMPORTANT TO COMPLETE A BURN-OFF. START THE GRILL AND OPERATE FOR A MINIMUM OF 15 MINUTES ON HIGH TO BURN-OFF THE UNIT. THIS WILL "HEAT CLEAN" THE INTERNAL COMPONENTS, DISSIPATE ODORS AND RID IT OF ANY FOREIGN MATTER.

**FINAL CHECK**

- Check that the control knobs work normally.
- Check that the gas hose is free of cracks and damage (it should always be done before using the barbecue).
- Check that the gas cylinder and hose do not come into contact with hot objects.

**GOOD ADVICE**

- **KEEP THE BARBECUE CLEAN.** A clean barbecue gives better effect, less smoke, less irregular flames and reduces the risk of fat burning.
- **PREHEAT THE BARBECUE** for 10-15 minutes at maximum temperature. After preheating, adjust the controls according to the type of grilling and the desired grilling result. Using too much heat can result in burnt and overcooked food.



1. Open lid during lighting.
2. Set all control knobs to the "OFF" position.
3. Open the cylinder/gas valve according to the operating instructions on tank.
4. Push and turn the control knob counter-clockwise to "HIGH".
5. Push the igniter button a few times until the burner lights.
6. If ignition does not occur within 5 seconds, turn valve to "OFF", wait 5 minutes, and repeat lighting instruction. After lighting, observe the burner flame. Make sure all burner ports are lit and flame height matches illustration shown.
7. If the above points do not work, follow Manual Lighting Procedure. If the burner goes out during operation, turn the control knobs to the "OFF" position. Wait five minutes before attempting to relight to allow any accumulated gas to dissipate.

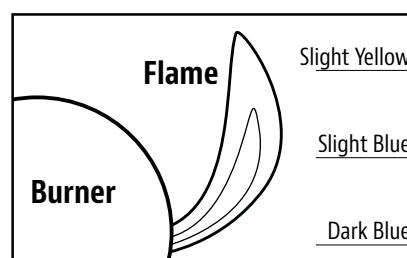

### DO NOT LEAN OVER THE BARBECUE WHILE LIGHTING!

#### MANUAL LIGHTING PROCEDURE

1. Open lid during lighting.
2. Set all control knobs to the "OFF" position.
3. Open the cylinder/gas valve according to the operating instructions on tank.
4. Quickly and carefully, use a lit match secured with the lighting rod (included with the grill) to light the burner. Gain access to the burner through the cooking grids. Position lit match near side of burner. Do not attempt to light another area of the burner. This can cause injury.  
**NOTE:** Do not use spirit, lighter-fluid or kerosene for lighting or refreshing a fire in your grill.
5. If the burner does not light within 5 seconds, turn burner control knob to "OFF", wait 5 minutes, and repeat lighting instruction. After lighting, observe the burner flame. Make sure all burner ports are lit and flame height matches illustration shown previously. Replace the Cooking Grid back into position, and you are ready to enjoy your grill at your desired temperature!  
**NOTE:** Each burner lights independently - repeat same steps

#### IGNITER FAILURE PROCEDURE

If for any reason your igniter fails after three of four attempts, check the following steps, or start your grill using the manual method.

1. Ensure the control knobs are turned to the OFF position. Allow any accumulated gas to dissipate.
2. After five minutes, check the following:

Visually confirm that the igniter is working by pushing the igniter button and looking at the igniter tip for a spark. If no spark, adjust the distance between the igniter (electrode) tip and burner to 4.5 mm.

Visually confirm that the burner tube and portholes are not obstructed. If blocked, follow Maintenance instructions.

3. If the above points do not work, follow Troubleshooting instructions.

**IF THE BURNER DOES NOT IGNITE, TURN THE SWITCHES TO THE OFF POSITION (CLOSE THE GAS SUPPLY) AND WAIT 5 MINUTES BEFORE TRYING TO IGNITE AGAIN.**



**IF THE BARBECUE STILL DOES NOT LIGHT WITH NORMAL OR MANUAL METHOD, READ THE TROUBLESHOOTING TABLE OR CONTACT YOUR DEALER.**

## KEEP THE FIREBOX, FLAME TAMERS, COOKING GRATE AND ACCESSORIES CLEAN TO AVOID GREASE FIRES.

### IF A GREASE FIRE OCCUR

In case of grease fire, close the gas supply on the regulator/barbecue and disconnect the regulator. In the event of a minor grease fire, wait until the fire goes out on its own. In the event of a major grease fire, use a suitable extinguishing agent (CO<sub>2</sub> appliance, fire blanket, etc.) and try to suffocate the fire.



**NB: DO NOT USE WATER TO EXTINGUISH GREASE FIRE!**  
**CLEAN THE BARBECUE REGULARLY TO AVOID GREASE FIRES.**

### HOW TO AVOID GREASE FIRE

Check the drip tray and grease cup after each grilling and clean regularly with a nylon brush and dishwashing detergent. How often it will be necessary to clean will depend on how much and type of food is grilled. To simplify cleaning we recommend adding cat litter and/or aluminum foil on the drip tray.

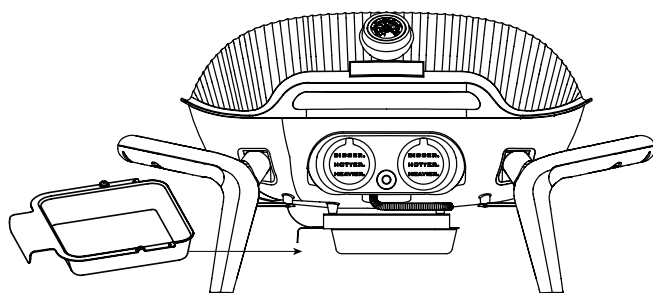

Clean the grill grate after grilling with a grill brush and, if necessary, with soap and water.

Clean flame tamers after grilling with a grill brush and, if necessary, with soap and water. In case of visible accumulation of grease and food residue in the firebox, remove these with a plastic scraper or use a nylon brush, water and dish soap.

During preheating, check that there are no signs of irregular flames. When grilling foods with much fat, pay extra attention. Feel free to use trays in aluminum foil to prevent large amounts from running down on flame tamers and on the grease tray.

Do not leave the barbecue when it is lit and close the gas supply as soon as possible if there is a sign of a grease fire.

### MAINTENANCE OF THE BARBECUE

- Check regularly that the burners are burning correctly.
- Remove the grill grate and flame tamers
- Light the barbecue in the normal way.
- Turn the control from low to high. Check if there is a difference in strength, and that the flame is clear and blue. The flame should not be orange. If the burner behaves abnormally, read the troubleshooting table.
- Remove grease and old food debris on the burners with a nylon brush and check that no holes in the burner are clogged.

### MAINTENANCE OF THE BURNERS

1. All controls must be in OFF mode. Check that the gas supply is switched off and the regulator is disconnected from the gas cylinder.
2. Remove the cooking grate, flame tamers and drip tray.
3. Remove the screws on the burner, use a screwdriver.
4. Carefully lift the burners out of the valve outlet.
5. Use a nylon brush to clean the outside of the burner.
6. Clean blocked passages/channels by using a metal string or e.g. bending a paper clip.
7. Check that insects, cobwebs etc. do not block the inside of the burner. In that case, remove this.
8. Check if the burner is damaged. Small holes and corrosion can occur with normal use of the barbecue. Are there cracks or holes, the burner should be replaced with a new one.
9. After cleaning, place the burner in place and screw it on.
10. Replace flame tamers, grease trays and grill grate.



**FIRES CAUSED BY FAT, CAN DAMAGE THE METAL, PAINT AND ENAMEL. DAMAGE TO THE BARBECUE CAUSED BY FAT BURNING, IS NOT COVERED BY THE GUARANTEE AS IT IS DUE TO INCORRECT USE.**

**CLEANING**

All cleaning and maintenance must be performed when the barbecue is cold. Make sure that the gas supply is switched OFF and the regulator is disconnected from the gas cylinder.

Use a mixture of dishwashing detergent and water, or use a separate grill cleaner with a nylon scrubbing brush / scouring sponge on the inside of the lid and in the inner grill body itself. Rinse well and allow to air dry completely. Do not use caustic soda, alcoholic or abrasive detergents. This can damage the barbecue and cause a fire. Cast iron cooking grate, drip tray and grease cup must not be cleaned in a dishwasher.

**PLASTIC PARTS**

Use only clean water and any mild detergents. Wipe with a clean cloth.

**BARBECUES IN CAST ALUMINUM**

Cast aluminum parts are varnished with a high-quality lacquer that can be damaged if abrasives grinding cleaning is used. Clean with a mixture of dishwashing detergent and water, or use a separate grill cleaner with a nylon scrubbing brush/scouring sponge on the inside of the lid and in the inner grill body itself. Outside of the barbecue use a soft sponge or microfiber cloth to clean painted surfaces. Rinse well and allow to air dry completely. Do not use caustic soda, alcoholic or abrasive detergents. This can damage the barbecue and cause a fire.

**Cast iron cooking grate, drip tray and grease cup must not be cleaned in a dishwasher.**

As a finishing step you can use polish or aluminum protector to give your bbq a protection from the elements. This is something we recommend 1-2 times pr year.

Barbecues in cast aluminum requires less maintenance than barbecues in other materials, but surface rust can appear if the step above is not followed.

**COOKING GRATE OG FLAME TAMERS**

Grill grate and flame tamers are brushed regularly with a grill brush for rough cleaning. The grill grate can be soaked in mild soapy water. For difficult, burnt stains, use a non-abrasive cleaner. Rinse well with water and dry well.

**NB! The grill grates must be completely dry before they are placed back in the barbecue. For main cleaning before storing the barbecue for a longer period, feel free to insert the grill grates with a thin layer of cooking oil.**

**INSECTS AND VERMIN**

After long-term storage, insects and other vermin can be found in the barbecue. If you experience problems with lighting or irregular flames, it can be due to unwanted guests blocking the gas supply. In such instances, dismantle and clean the burners. Replace the burners when they are dry.

- Disassemble the burners and clean them if pests are suspected in the barbecue. Refit the burners when they are completely dry.
- Check that the gas hose is not cracked or damaged by mice or rats.

**To avoid rust damage, we recommend protecting the barbecue with a fitted barbecue cover, or that you do not store the barbecue out in the open or expose it to rain.**

### SAFETY AND INFORMATION

- The gas cylinder should always be placed next to the barbecue when in use.
- Close the gas supply on the regulator when the barbecue is not in use and when storing the gas cylinder under the barbecue, disconnect the regulator.
- If the barbecue is stored in a garage or basement below ground level, the gas cylinder should not be stored in the same place.
- If the barbecue has a side burner, the circumference of the pots and pans used must not be larger than the opening on the side burner.  
If oversized accessories are used, the heat will be trapped inside which will create an overheating that can damage the barbecue.
- THIS PRODUCT IS INTENDED FOR USE IN PRIVATE HOUSEHOLDS AND IS NOT SUITABLE FOR PROFESSIONAL USE IN A RESTAURANT OR SIMILAR.
- Coatings should not be applied until the barbecue is completely cold and dry. Moisture on the inside of the cover will cause large formations of surface rust for those of the grill parts which are in painted steel and stainless steel.
- AVOID STORAGE OF The barbecue IN DIRECT SUNLIGHT, AS PARTS OF THE BARBECUE THAT CONTAIN STAINLESS STEEL OR GLASS MAY REFLECT SUNLIGHT AND CAUSE FIRE.
- PARTS IN PLASTIC WILL BE ABLE TO BLEACH UNDER THE INFLUENCE OF SUNLIGHT.
- LACQUERED PARTS WILL BE ABLE TO WHITE WITH THE EFFECT OF SUNLIGHT.

### ADVICE AND TIPS

- Always preheat the barbecue for 10-15 minutes before starting to grill. Then the cast iron grates are taken up and distributed evenly over the barbecue surface.
- Outdoor temperature, wind, snow and rain can give a deviation of up to 30% on the temperature shown in the thermometer and the temperature that is actually on the barbecue surface.
- Make sure that the barbecue is on a stable and straight surface to prevent grease from leaking out of the grease collection system.
- To facilitate cleaning of grease trays, cat litter can be used to absorb grease.
- Make sure that the barbecue is stored dry under a roof or under a cover. Water from snow, ice and rain that enters the barbecue can overflow the grease collection system and cause leakage to the surface.
- We recommend the use of FCC BBQ original covers for the best possible protection against rain, pollen and pollution. Remember that the barbecue must be completely dry and cold before applying the coating. The coating is equally waterproof both ways and moisture on the inside can cause major rust damage on painted and stainless steel surfaces.

PROBLEM	POSSIBLE CAUSE	SOLUTION
<b>BURNER WILL NOT LIGHT</b>	Empty gas cylinder	Replace gas cylinder
	Damaged regulator	Check/replace the regulator
	Burner is blocked	Clean the burner
	Gas supply is blocked	Clean gas ventury or hose
	Electrode is broken or dirty	Clean the electrode
	Windy conditions	Place the barbecue in a less exposed position
	Ignition wire is damaged or fitted incorrectly	Make sure wire is mounted correctly
<b>LOW FLAME</b>	Empty gas cylinder	Replace gas cylinder
	Irregular gas supply	Check/replace the regulator
	The burner is blocked	Clean the burner
	Gas supply or hose is blocked	Clean gas ventury or hose
<b>LOW FLAME OR BACKFIRE</b>	Gas cylinder is too small	10 kg or larger cylinder is recommended
	Burner is blocked	Clean the burner
	Gas supply or hose is blocked	Clean gas ventury or hose
	Windy conditions	Place the barbecue in a less exposed position
<b>TROUBLE TURNING THE KNOBS</b>	Gas valve jammed	Replace gas valve. NB! Knobs should be pressed in and turned
<b>HEAVY SMOKE</b>	Fatty foods on the barbecue	Trim away excess fat from meat. Clean the fat tray

F C C  
B B Q

CHEF'S TABLE  
T O P

### WARRANTY CLAIM

This product is covered by a warranty in accordance with consumer legislation. It has undergone strict quality controls and testing at the factory. If there are any parts missing or the product has been damaged, please contact your dealer or the consumer contact below for help.

In the event of damage to the product, we ask for pictures of the damage and damage to the product's packaging is attached to the complaint.

Faults due to misuse, lack of maintenance or modification of the product will invalidate the warranty. Damaged parts not due to a fault with the product will be invoiced according to our price list + carriage and administration fee.

If new parts are needed or in the event of a warranty claim, please contact your dealer or consumer contact:

### FCC PRODUCTS AS

KJELLER VEST 3, 2007 KJELLER,  
NORWAY



+47 924 78 600

Support opening hours: Mon-Fri 10:00-14:00

✉ support@fccbbq.com

FCCBBQ.NO

FCCBBQ.SE

FCCBBQ.COM

**Always attach your receipt and product serial number when making a warranty claim.**

---

PRODUCED IN CHINA FOR FCC PRODUCTS

We are always looking for ways we can improve our products. Therefore, we reserve the right to change technical specifications at any time. You will always find the latest manual on [WWW.FCCBBQ.COM](http://WWW.FCCBBQ.COM).