

**F C C**  
**B B Q**

*by The Flying Culinary Circus*



SCAN QR CODE AND  
REGISTER BARBECUE FOR  
EXTENDED WARRANTY



SCAN QR CODE FOR  
BARBECUE  
ASSEMBLY VIDEO



# MANUAL

Assembly, use, maintenance and safety



FCC-G-21100-31 / F3B



**OUTDOOR USE ONLY**  
READ THE MANUAL, FOLLOW THE  
ASSEMBLY INSTRUCTIONS STEP BY  
STEP. GET TO KNOW YOUR GRILL AND  
THE SAFETY INSTRUCTIONS BEFORE  
USING THE APPLIANCE!

*Share the fun of cooking!*

Warnings .....	3
Technical data .....	4
Read before assembly .....	5
Parts list .....	6
Assembly .....	8
Regulator and hose .....	16
Check for leaks before using the barbecue .....	17
Last check .....	18
Lighting instructions .....	19
Maintenance .....	20
Advice, tips and safety .....	22
Troubleshooting .....	23
Consumer contact .....	24



- ACCESSIBLE PARTS OF THE BARBECUE BECOME VERY HOT DURING USE. KEEP CHILDREN AND OTHERS WHO NEED SUPERVISION AT A SAFE DISTANCE.
- THE BARBECUE IS INTENDED FOR OUTDOOR USE ONLY IN WELL-VENTILATED AREAS.
- LEAK TESTS (SEE PAGE 17) MUST ALWAYS BE CARRIED OUT BEFORE THE BARBECUE IS USED AND WHEN REPLACING THE GAS CONTAINER. ALSO PERFORM A LEAK TEST IF THE PRODUCT HAS NOT BEEN IN USE FOR A LONG TIME AND IN ADVANCE OF A NEW BARBECUE SEASON. ALWAYS CHECK THE GAS HOSE FOR DAMAGE AND CRACKS BEFORE USING THE BARBECUE.
- NEVER BARBECUE IN CLOSED ROOMS OR UNDER ROOFS, AS THIS MAY LEAD TO A LACK OF OXYGEN.
- FAILURE TO FOLLOW THE INSTRUCTIONS PROVIDED CAN IMPLY A RISK OF SERIOUS INJURY TO PERSONNEL AND FIXED INSTALLATIONS.
- REBUILDING / MODIFYING THE BARBECUE CAN CAUSE DANGER AND WILL INVALIDATE THE WARRANTY.
- ALWAYS SUPERVISE THE BARBECUE DURING USE AND KEEP SUITABLE EXTINGUISHING EQUIPMENT WITHIN REACH. THE BARBECUE SHOULD NOT BE OPERATED BY INTOXICATED PERSONS.
- THE BARBECUE MUST NOT BE USED IN PLACES THAT ARE BELOW NORMAL GROUND LEVEL. GAS CAN ACCUMULATE AND REPRESENT A DANGER OF EXPLOSION. GAS ACCUMULATION CAN ALSO CAUSE OXYGEN DEFICIENCY.
- THE BARBECUE MUST BE CLEANED REGULARLY AND THOROUGHLY TO PREVENT UNCONTROLLED GREASE FIRE. READ MORE ABOUT GREASE FIRE ON PAGE 20

ALSO READ PAGE 22 FOR MORE ADVICE AND TIPS ON GRILLING AND SAFETY..

## Technical Data

**Total Heat input:** 13.2 kW (main burner: 9.9kW + side burner: 3.3kW)

**Gas consumption:** G30 959.8g/h / G31 942.7g/h

**Gas cylinder (not included):** Use standard cylinder approved for use in the Nordic Region. Even though butane and propane gas can be used, we recommend propane for use in the Nordic Region. Approved hoses and regulators are available from most outlets selling gas equipment.

**NB!** Gas hoses used for this product must not exceed 120 cm in length.

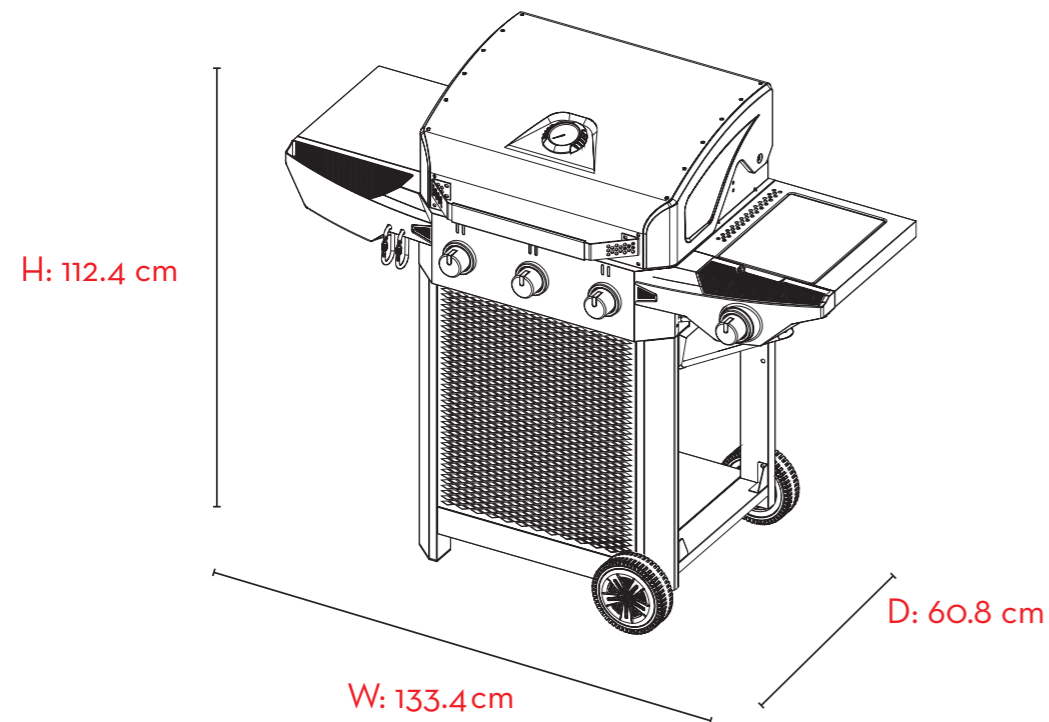

USE ONLY GAS TYPE AND GAS CATEGORY ENTERED IN THIS MANUAL.

DESTINATION OF COUNTRIES TO USE	VALVE SIZE	GAS TYPE	GAS CATEGORY
BE, BG, CY, CZ, DK, EE, FI, FR, GB, GR, HR, HU, IT, LT, LU, LV, MT, NL, NO, RO, SE, SI, SK, TR	ø0.89 mm main burner ø0.89 mm side burner	G30(Butane) G31(Propane) and their mixtures	I3B/P(30)

CE 1336-22

The product is manufactured in accordance with European Gas Appliances Regulation (EU) 2016/426

## Read before assembly

### FOLLOW THESE INSTRUCTIONS CAREFULLY TO AVOID SERIOUS PERSON INJURY OR DAMAGE TO YOUR BARBECUE.

Make sure that all parts and screws are included and that they are undamaged before assembling the product.

**If the barbecue is damaged during transport, do not assemble the barbecue before contacting your dealer or [support@fccbbq.com](mailto:support@fccbbq.com).**

Transport damage to parts, varnish or enamel must be reported to the dealer or [support@fccbbq.com](mailto:support@fccbbq.com) before the barbecue is installed and used.

**Please note that some parts may be located in the Styrofoam to protect the part during transport. If parts are missing, first check the packaging carefully.**

Compare the parts list with the contents of the box. Do not assemble this grill if there is damages or parts are missing, contact your dealer or [support@fccbbq.com](mailto:support@fccbbq.com).

Remove all remnants of packaging material and any plastic wrap from the barbecue.



- FOLLOW THE ORDER IN THIS MANUAL TO AVOID INCORRECT ASSEMBLY. PARTS OF THE ASSEMBLY WILL REQUIRE HEAVY LIFTING WHICH SHOULD BE PERFORMED BY TWO PEOPLE TOGETHER, TO AVOID PERSONAL INJURY AND DAMAGE TO THE BARBECUE. SOME METAL PARTS MAY BE SHARP, WEAR PROTECTIVE GLOVES.
- POWER TOOLS SHOULD NOT BE USED TO ASSEMBLE THE BARBECUE. TOOLS WITH TOO MUCH FORCE CAN DAMAGE THE SURFACE TREATMENT ON SCREWS, DAMAGE ENAMELLED / LACQUERED PARTS OF THE BARBECUE, AS WELL AS LOOSEN PRE-ASSEMBLED NUTS.
- IF THE PRODUCT'S VARNISH OR ENAMEL IS DAMAGED DURING ASSEMBLY, WE RECOMMEND THAT THE DAMAGE BE TREATED IMMEDIATELY TO AVOID LATER RUST DAMAGE. SUITABLE HEAT-RESISTANT VARNISH CAN BE ORDERED FROM [SUPPORT@FCCBBQ.COM](mailto:SUPPORT@FCCBBQ.COM).

## Parts list

CODE	DESCRIPTION	QTY
1	GAS GRILL ASSEMBLY	1
2	WARMING RACK	1
3	BIG COOKING GRATE (FOR MGS)	1
4	FLAME TAMER	3
5	LEFT SHELF	1
6	CARABINE HOOK	2
7	SIDE BURNER FRAME	1
8	SIDE BURNER	1
9	RIGHT SHELF	1
10	CONTROL KNOB BASE	1
11	CONTROL KNOB	1
12	LEFT REAR CORNER BRACE	1
13	LEFT SIDE UPPER BRACE	1
14	LOWER BRACE	2
15	LEFT FRONT CORNER BRACE	1
16	FRONT PANEL	1
17	LOWER FRONT PLATE	1
18	FRONT TRIM ON RIGHT SHELF	1
19	BOTTOM SHELF	1
20	TOP SUPPORT	1
21	RIGHT FRONT CORNER BRACE	1
22	RIGHT SIDE UPPER BRACE	1
23	RIGHT REAR CORNER BRACE	1
24	WHEEL COVER	2
25	WHEEL	2
26	AXLE	1
27	HEAT REFLECT PANEL	1
28	GREASE TRAY	1
29	OIL CUP	1
30	SMALL COOKING GRATE	1
31	ROUND COOKING GRATE	1

## Parts list

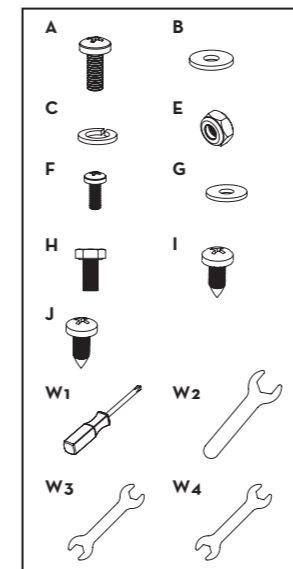
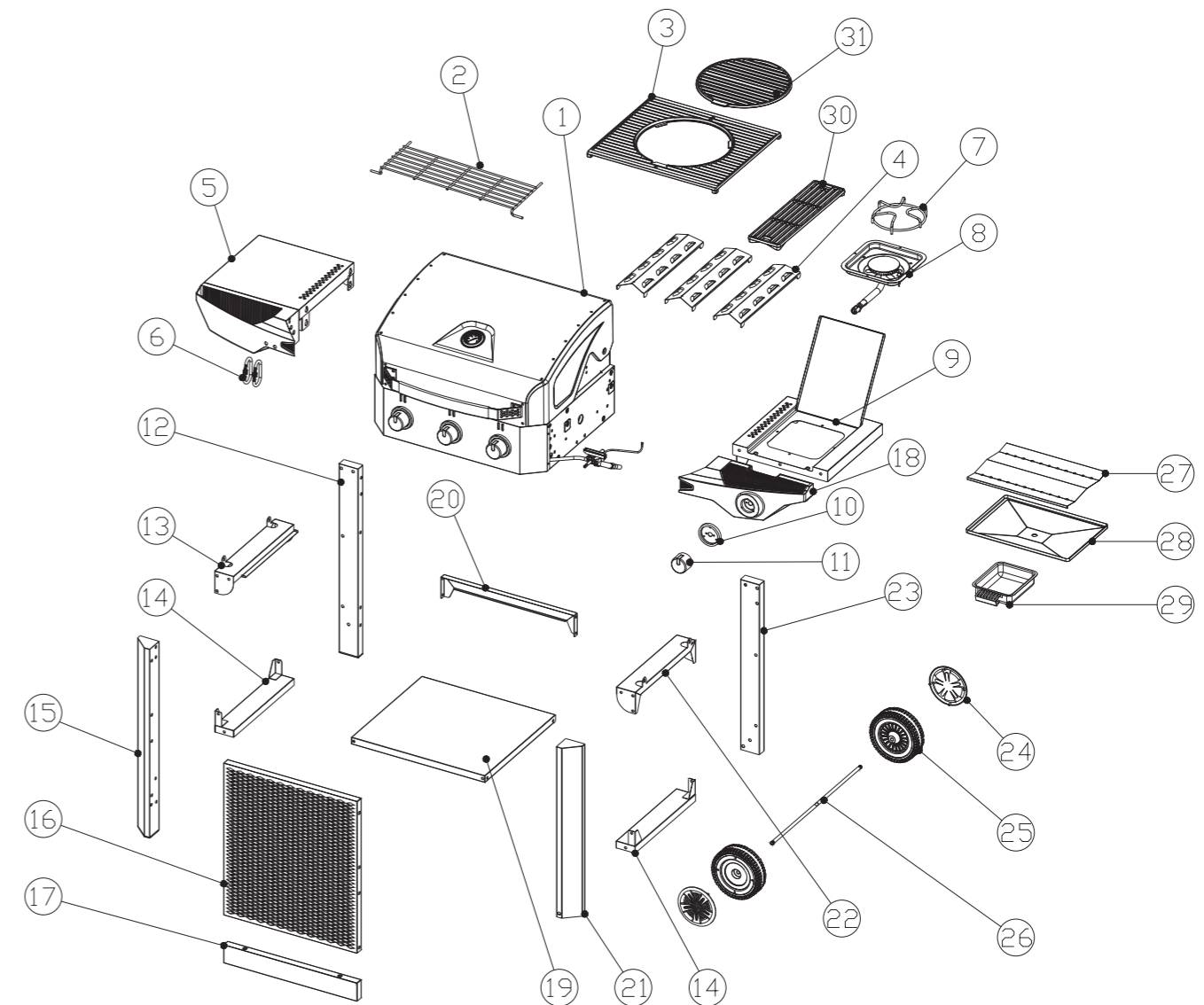

CODE	DESCRIPTION	QTY
A	SCREW M6x15	54+3
B	WASHER Ø6	6+3
C	LOCK WASHER Ø6	3+2
E	M10 NUT	2
F	SCREW M4x10	6
G	FIBER WASHER	4
H	SCREW M6x15	3
I	SCREW ST6.3x16	3
J	SCREW ST4.2x10	3
W1	PHILIPS SCREWDRIVER	1
W2	HEX WRENCH 17	1
W3	HEX WRENCH 7	1
W4	HEX WRENCH 10	1

NB! Number after "+" are spare parts.

# Assembly

## 1.

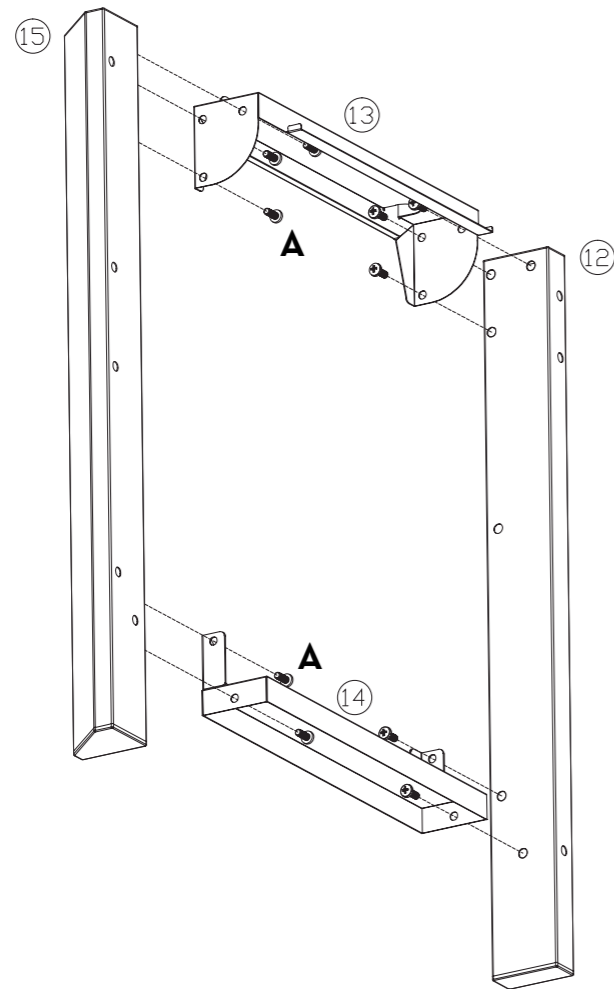

RIGHT SIDE

Assemble the corner braces with the lower and upper braces with 10 pcs M6x15 screws.

## 2.

LEFT SIDE

Assemble the corner braces with the lower and upper braces with 10 pcs M6x15 screws.

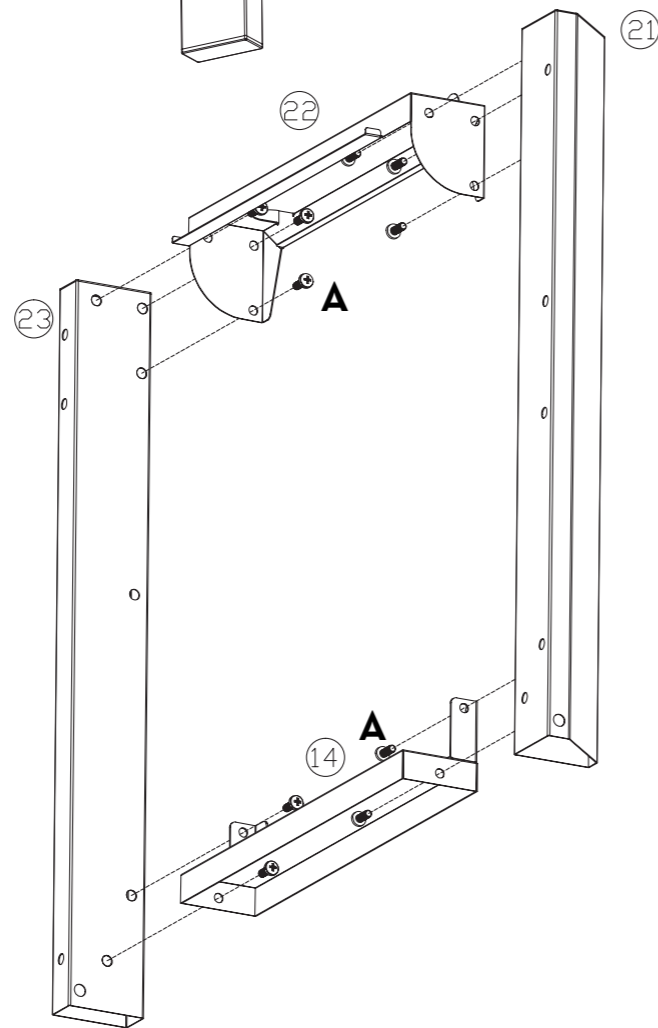

8

# Assembly

## 3.

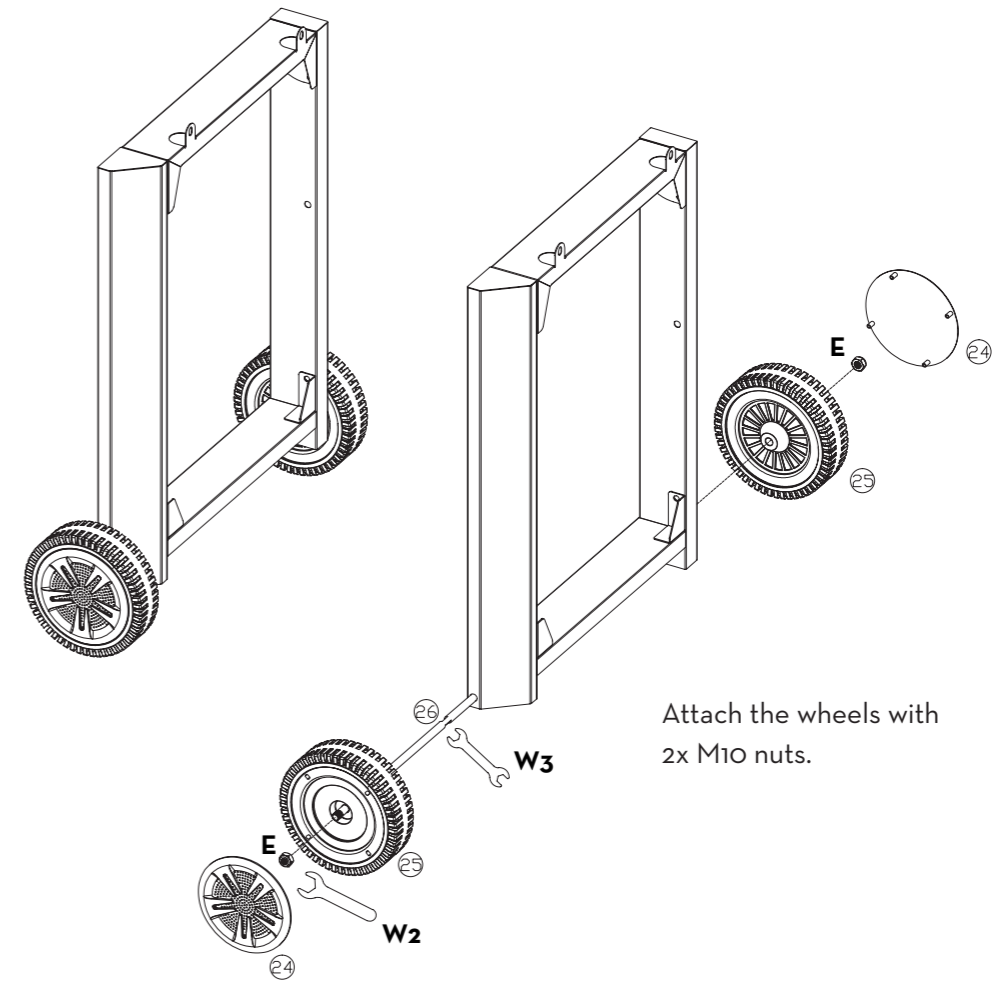

Attach the wheels with 2x M10 nuts.

## 4.

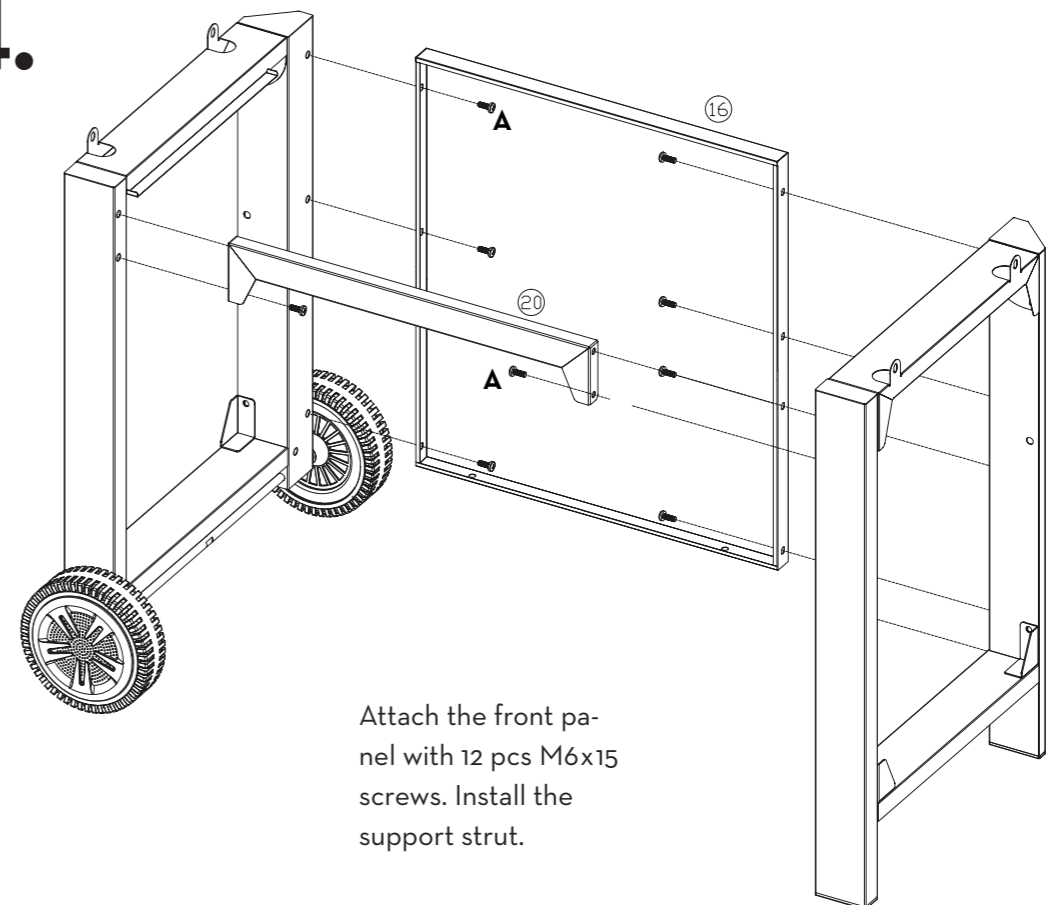

Attach the front panel with 12 pcs M6x15 screws. Install the support strut.

9

Assembly

5.

Turn the carriage upside down and install the bottom plate with 4 pcs M6x15 screws.

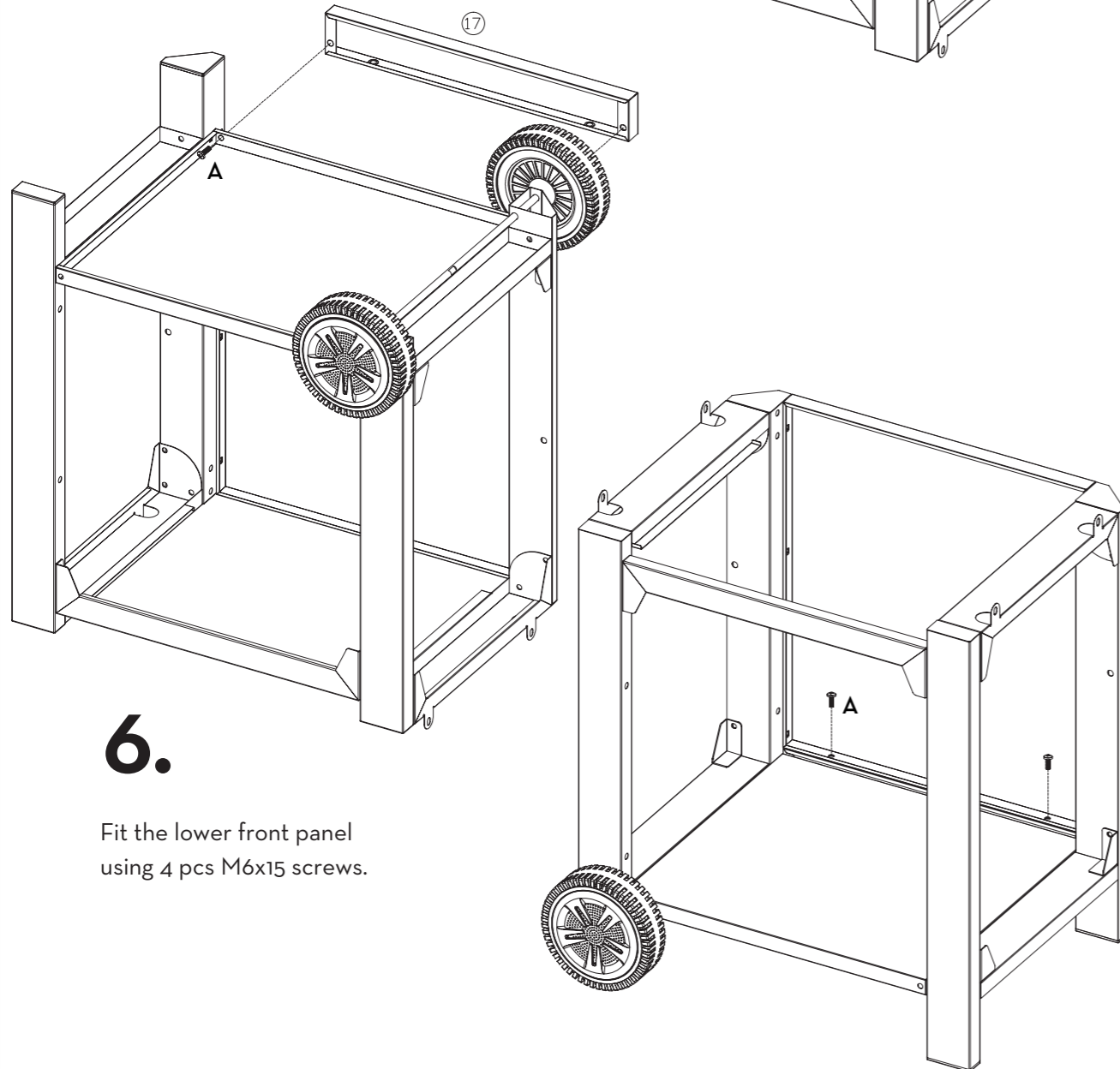
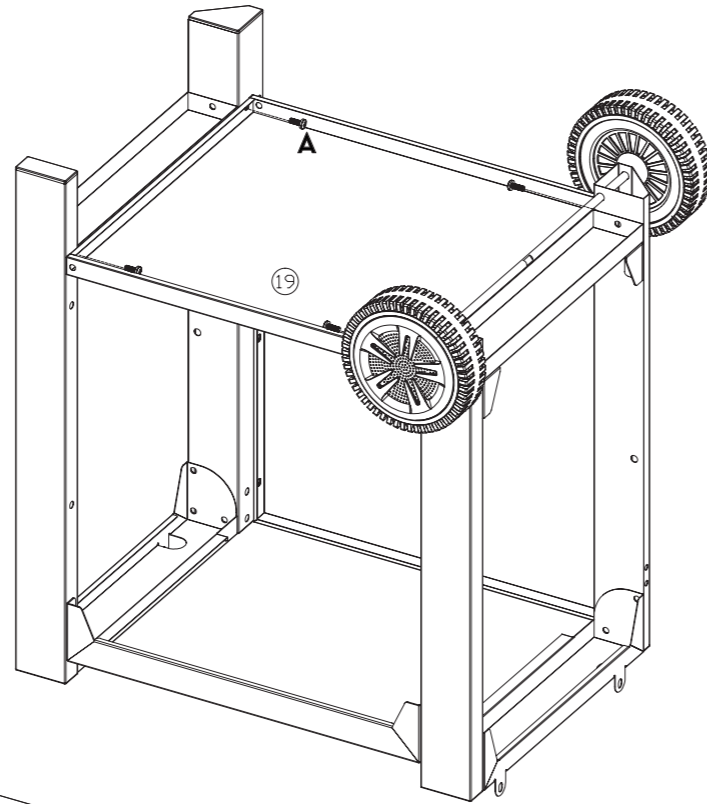

6.

Fit the lower front panel using 4 pcs M6x15 screws.

10

Assembly

7.

**NOTE!**  
TWO PERSONS IS RECOMMENDED WHEN LIFTING THE STOVE BODY.

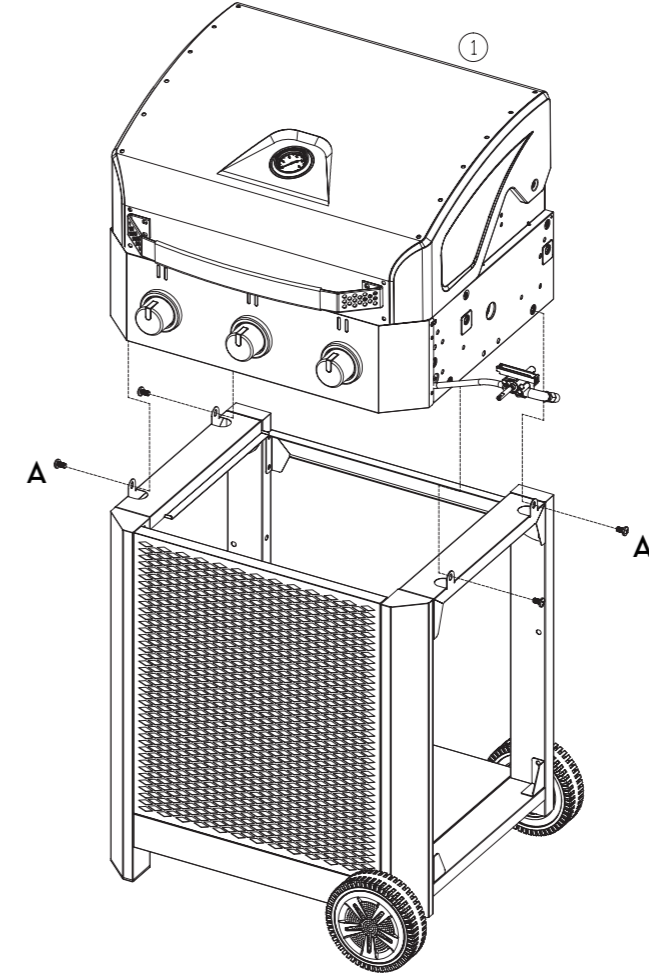

Lift the grill body and place it on the base.  
Fit the 4 screws (M6x15) before tightening.

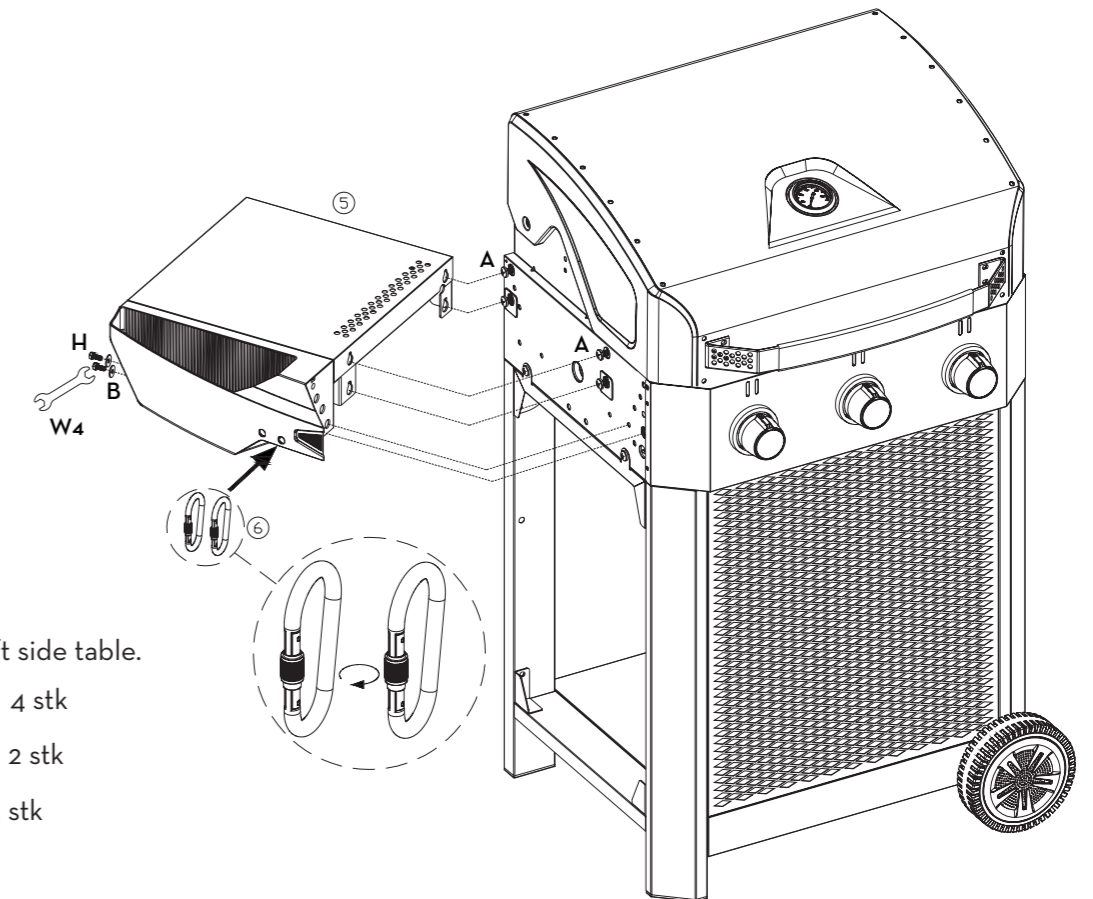

8.

Fit the left side table.

- A. M6x15 4 stk
- H. M6x15 2 stk
- B. Ø6.5 2 stk

11

## Assembly

### 9.

Assemble the front panel and left side table.

I. ST6.3x16 3 stk

B. Ø6.5 3 stk

C. Ø6.5 3 stk

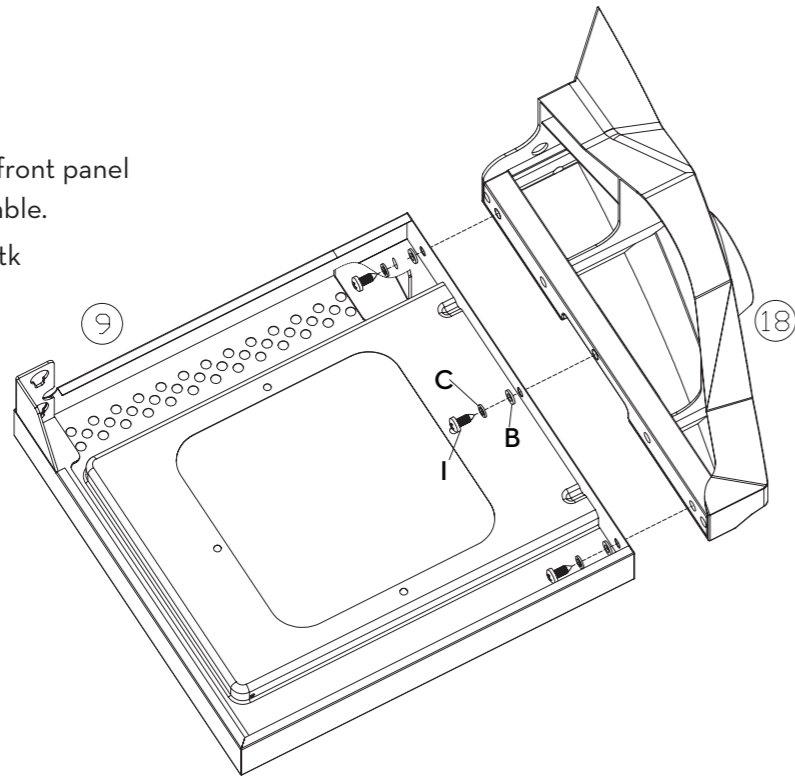

### 10.

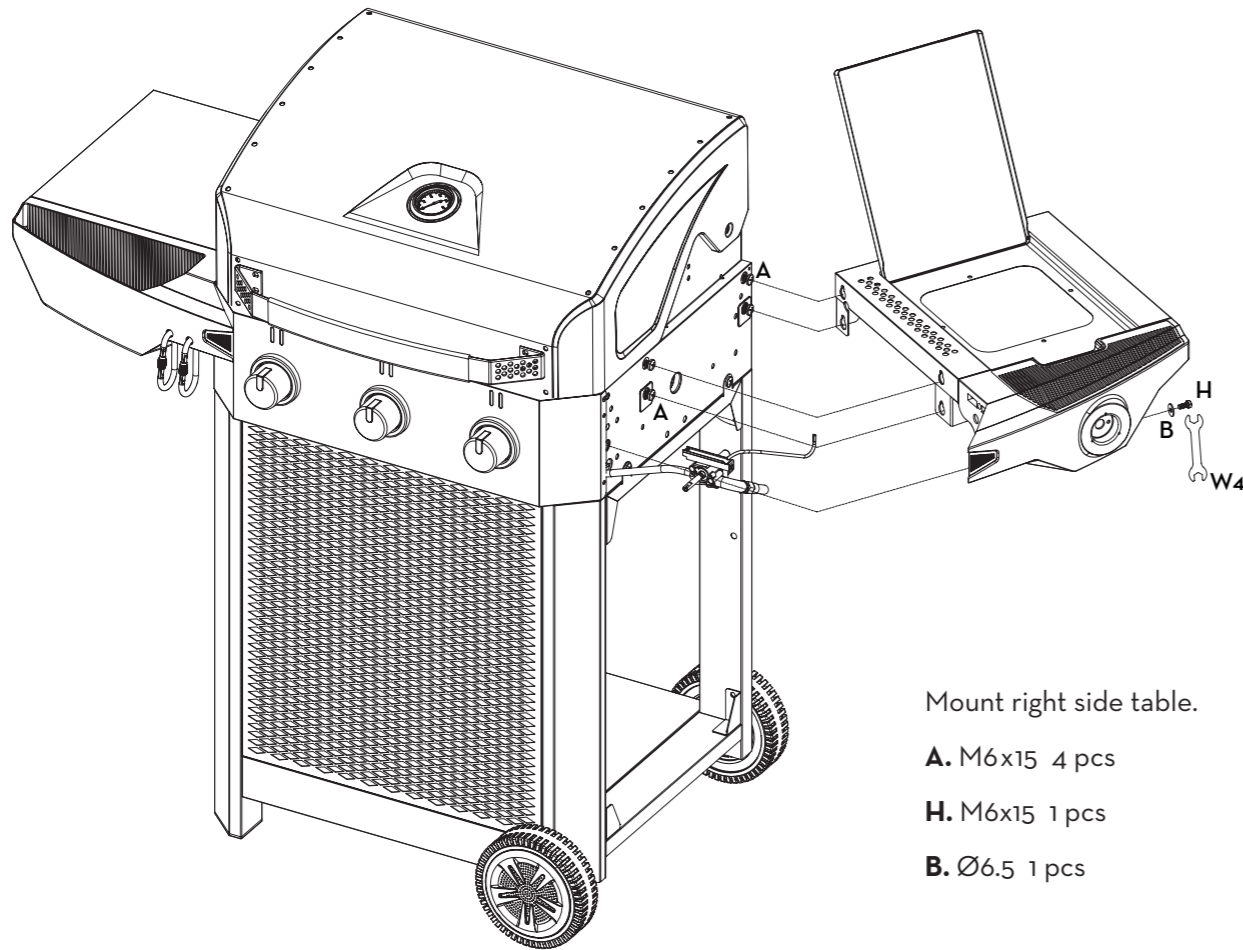

Mount right side table.

A. M6x15 4 pcs

H. M6x15 1 pcs

B. Ø6.5 1 pcs

12

## Assembly

### 11.

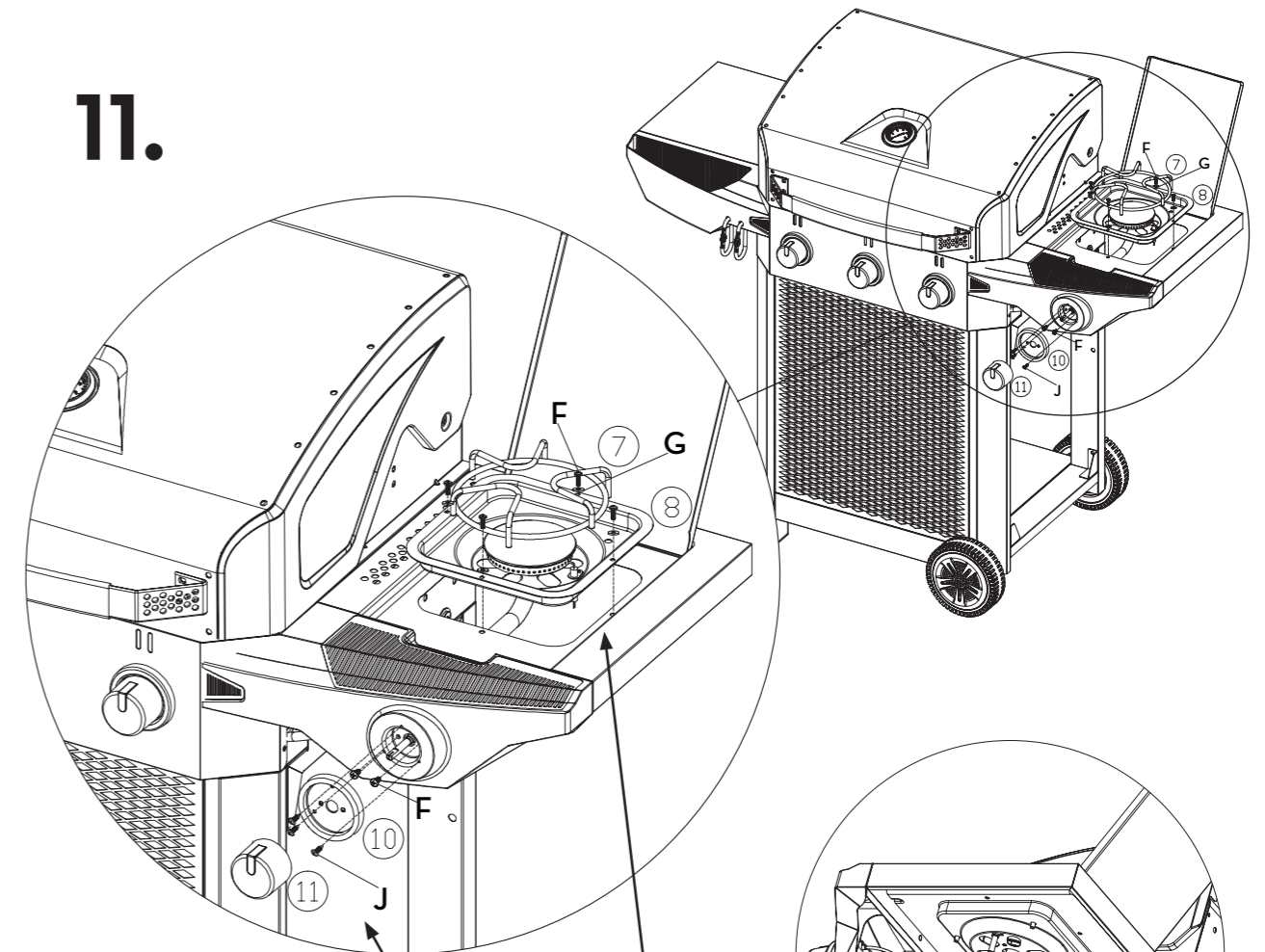

F. M4x10 6 pcs

G. Fiber Washer 4 pcs.

J. ST4.2x10 3 pcs

**Step 1:** Use M4\*10 (F) to lock the side burner and the right plate plastic.

**Step 2:** Use ST4.2x10 (J) to install the knob base.

**Step 3:** Install the knob (11).

**Step 4:** Attach the side burner (8) with screw M4 x 10 (F) and fiber washer (G).

**Step 5:** Put the side burner frame (7) on top.

**Step 6:** Plug in the ignition wire.

13

# 12.

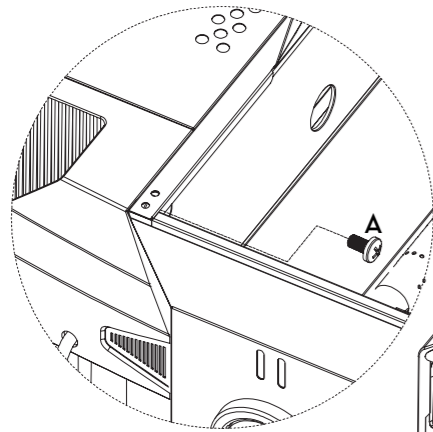

Attach the side tables with 2 pcs M6x15 screws.

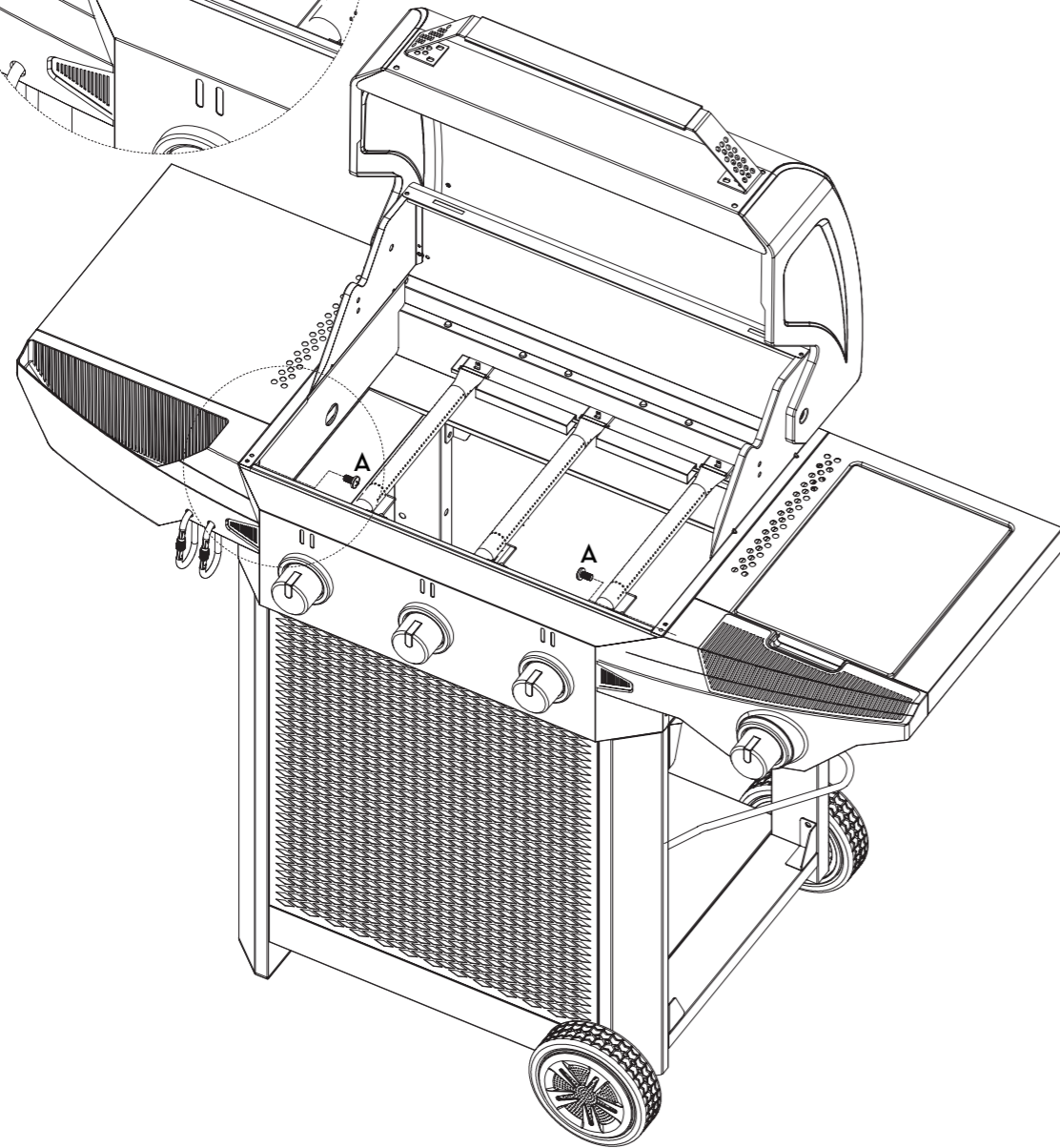

# 13.

Add flame tamers.  
Insert the grill grate and warming shelf.

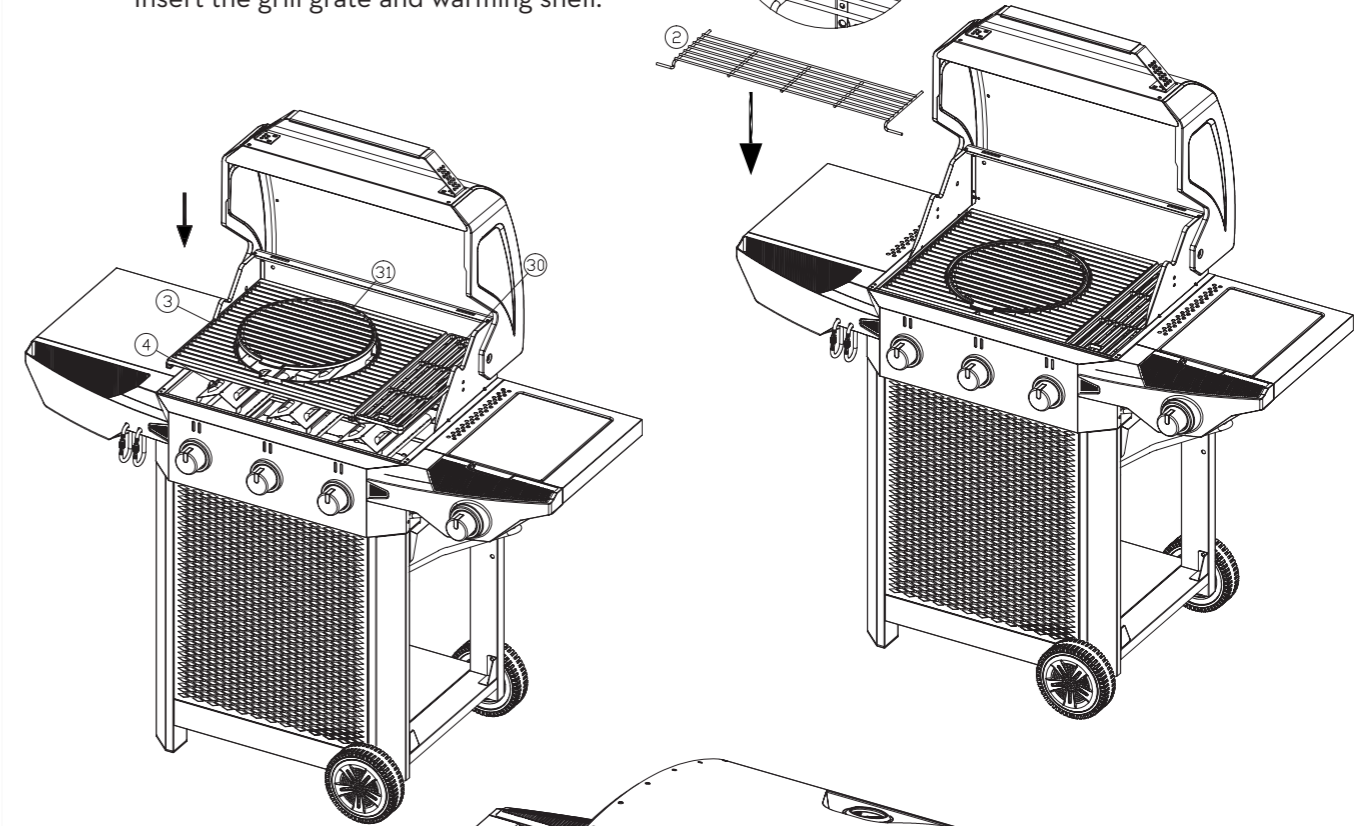
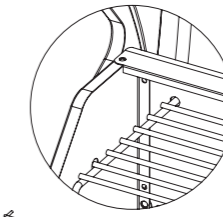

Place the plate in the grease tray and push it into the back of the barbecue.  
Push in the grease cup.

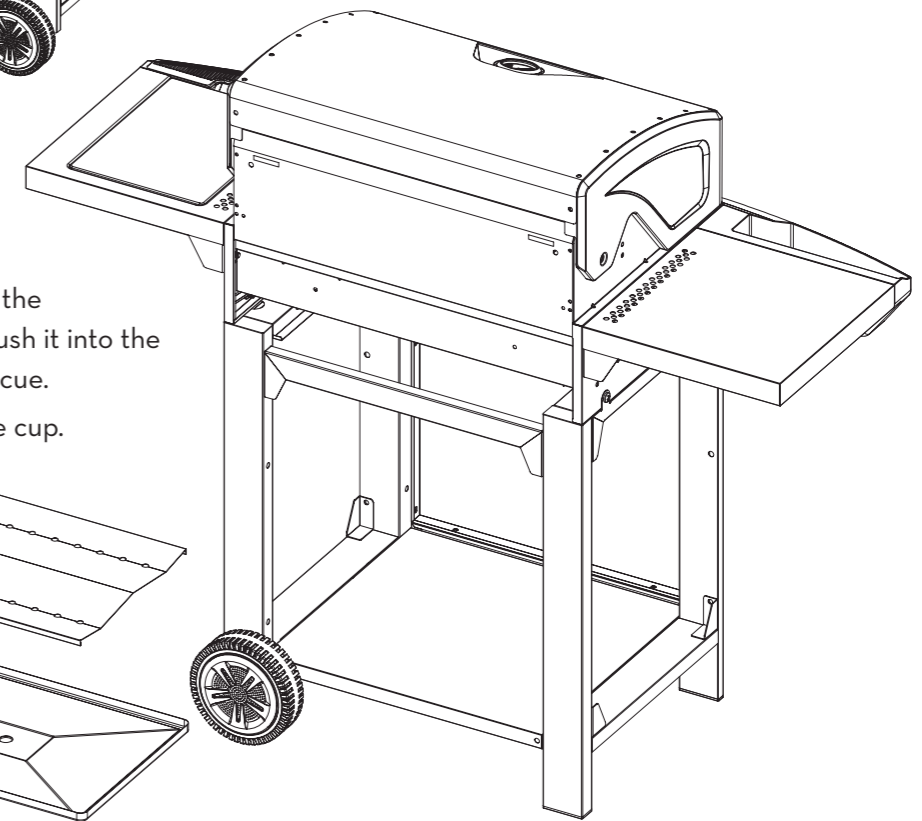
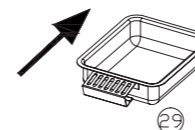
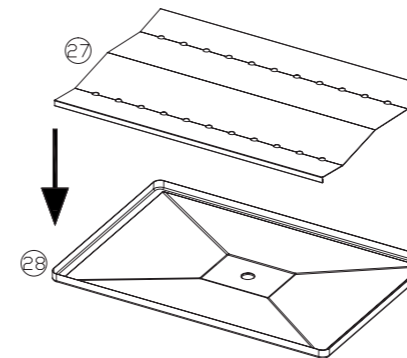

The barbecue is now fully assembled.



### FOLLOW THESE INSTRUCTIONS CAREFULLY TO AVOID SERIOUS DAMAGE TO YOUR BBQ AND CAUSE PERSONAL INJURY.

#### HOSE

- Connect the gas hose to the gas inlet on the barbecue. Tighten well.
- Install the regulator and hose. Follow the installation instructions that came with the controller set.
- Do not use sealing tape, glue or liquid on the connection.
- Gas hoses used for this product must not be longer than 120 cm.
- Check the gas hose regularly for cracks, damage and rot. Never use a damaged gas hose.

#### REGULATOR

- Check that all controls on the control panel are in the OFF position before connecting the regulator to the gas cylinder.
- Connect the regulator to the gas cylinder according to your regulator and the cylinder dealer's instructions.
- We recommend propane gas for use in the Nordic countries, but butane can also be used. Butane is poorly suited for low temperatures.
- Check that the regulator is not damaged.
- Check that the gas container is on a firm, level surface and is lower than the gas inlet on the barbecue.
- Use an approved gas cylinder that fits the regulator. Cylinders of 10 kg or more are recommended.

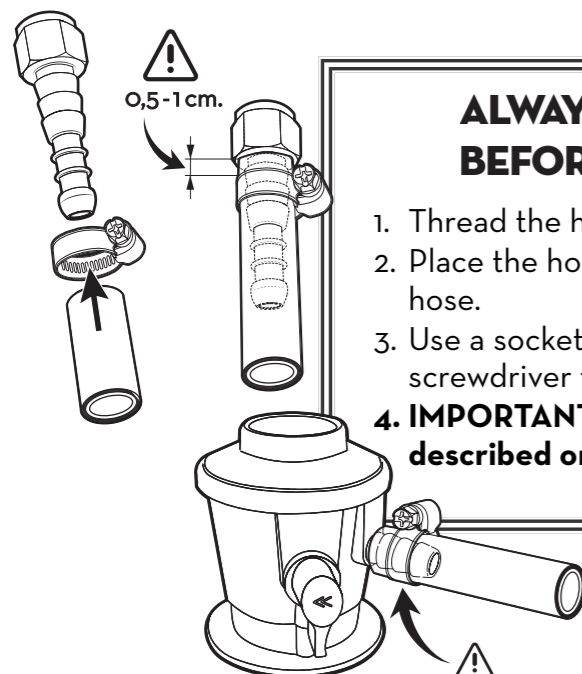

#### ALWAYS PERFORM A LEAK TEST BEFORE USING THE BARBECUE!

1. Thread the hose all the way into the gas nipple.
2. Place the hose clamp 0.5 - 1 cm from the end of the hose.
3. Use a socket wrench (size 7), wrench (size 7) or screwdriver to tighten the hose clamp and tighten well.
4. **IMPORTANT! A gas leak test must be performed as described on next page before using the barbecue.**

### BEFORE USING THE BARBECUE, A LEAK TEST MUST BE CARRIED OUT!

Never check for leaks by using an open flame, use a leak spray or alternatively a soapy water mixture (two parts dishwashing soap and one part water).



1. Extinguish all live flames, heat sources and cigarettes in the area where the leak test is to be performed.
2. Turn all controls on the barbecue to the OFF position.
3. Set the regulator to the OFF position and connect it to the gas tank.
4. Spray the leaking spray (or brush the soap mixture) on all joints and connections on the gas container, regulator, the entire hose and all valves on the barbecue.
5. Open the gas supply on the regulator and carefully check for bubbles in any of the places where the spray/mixture is applied.

- !**
6. **IF BUBBLES OCCUR, CLOSE THE GAS SUPPLY AND TIGHTEN ALL CONNECTIONS / JOINTS. THEN DO A NEW TEST. THE BARBECUE MUST NOT BE USED UNTIL YOU ARE SURE THERE ARE NO LEAKS. GAS LEAK CAN CAUSE UNCONTROLLED FIRE WHICH MAY INJURY PERSONS, FIXED INSTALLATIONS AND YOUR BARBECUE.**

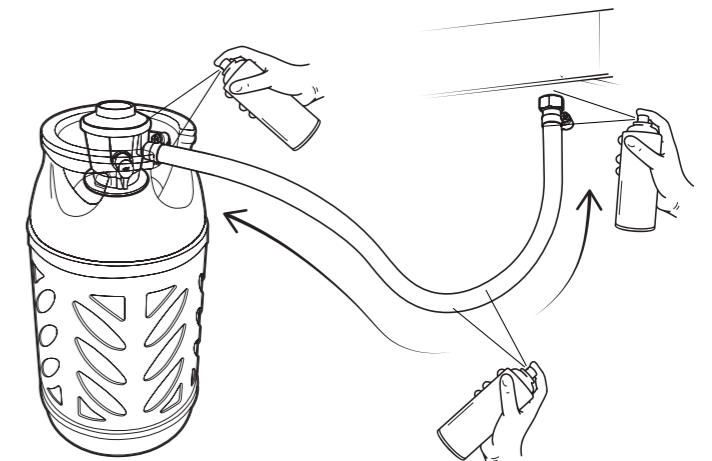

7. If detected leakage cannot be rectified, do not attempt to cure leakage but consult your dealer or FCC BBQ support på [support@fccproducts.no](mailto:support@fccproducts.no) for help in solving the problem.

- !**
- LEAK TEST MUST BE DONE REGULARLY AND EVERY TIME THE GAS CONTAINER, REGULATOR OR HOSE IS REPLACED.
  - ALSO TEST BEFORE NEW BARBECUE SEASON AND IF THE BARBECUE HAS NOT BEEN USED FOR A WHILE.

## Last Check

### PLACEMENT OF THE BBQ

- Ensure that the barbecue is placed at least 150 cm in all directions from house walls, trees, plants and other flammable materials or liquids when in use.
- Do not place the barbecue under a roof or overhang.
- Make sure that the barbecue is placed in a well-ventilated place to avoid carbon monoxide poisoning.
- The barbecue must not be used below normal ground level, as this can lead to an explosion hazard and a risk of lack of oxygen.



### FINAL CHECK

- Check that the control knobs work normally.
- Check that the gas hose is free of cracks and damage (it should always be done before using the barbecue).
- Check that the gas cylinder and hose do not come into contact with hot objects.

### GOOD ADVICE

- **KEEP THE BARBECUE CLEAN.**  
A clean barbecue gives better effect, less smoke, less irregular flames and reduces the risk of fat burning.
- **PREHEAT THE BARBECUE** for 10-15 minutes at maximum temperature. After preheating, adjust the controls according to the type of grilling and the desired grilling result. Using too much heat can result in burnt and overcooked food.

## Lighting Instructions

### LIGHTING INSTRUCTIONS

1. Set all control knobs to off (red bar pointing upwards).
2. Open the lid. The lid must always be open when lighting the barbecue.
3. Open the gas valve of the gas cylinder.
4. Push the knob of the desired burner in and turn it to the left. The burner will ignite automatically.
5. Wait until the burner is lit, then the next burner may be lit with the same procedure.  
Ignite the rest of the burners the same way as needed.

**TIPS:** Preheat the barbecue for about 10-15 minutes on maximum temperature. After completion of preheating, turn all burners to the "LO" position for best cooking results.

If the burners do not ignite after 5 seconds, set all control knobs to off (red bar pointing upwards) and close the gas valve of the gas cylinder. Wait for 5 minutes. Repeat the above procedure.

### MANUAL LIGHTING

If the electric ignitor of the appliance does not work or you like to light the appliance manually using a long match or a fireplace lighter:

**Do not lean over the barbecue while lighting!**

1. Set all control knobs to off (red bar pointing upwards).
2. Open the lid.
3. Open the gas valve of the gas cylinder.
4. Light a long match and enter it into the burner ports on the left or right sidewall of the firebox.
5. Push the control knob of the adjacent burner in, and turn it to the left.
6. Make sure the burner lights and stays lit.
7. Adjacent tube burners can be lighted by pushing their knobs in and turning them to the left.

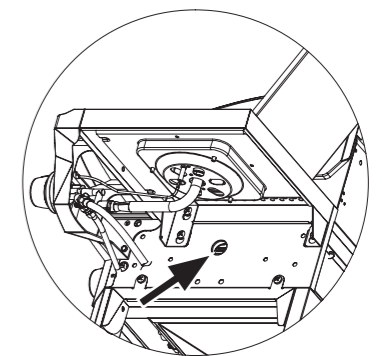

If the burners do not ignite after 5 seconds, set all control knobs to off (red bar pointing upwards) and close the gas valve of the gas cylinder. Wait for 5 minutes. Repeat the above procedure.

- ! IF THE BURNER DOES NOT IGNITE, TURN THE SWITCHES TO THE OFF POSITION (CLOSE THE GAS SUPPLY) AND WAIT 5 MINUTES BEFORE TRYING TO IGNITE AGAIN.
- ! IF THE BARBECUE STILL DOES NOT LIGHT WITH NORMAL OR MANUAL METHOD, READ THE TROUBLESHOOTING TABLE OR CONTACT YOUR DEALER.

## KEEP THE FIREBOX, FLAME TAMERS, COOKING GRATE AND ACCESSORIES CLEAN TO AVOID GREASE FIRES.

### IF A GREASE FIRE OCCUR

In case of grease fire, if possible close the gas supply on the regulator / barbecue and disconnect the regulator. In the event of a minor grease fire, wait until the fire goes out on its own. In the event of a major grease fire, use a suitable extinguishing agent (CO<sub>2</sub> appliance, fire blanket, etc.) and try to suffocate the fire. **NB! NEVER USE WATER TO EXTINGUISH A GREASE FIRE.**

**! NB: DO NOT USE WATER TO EXTINGUISH GREASE FIRE! CLEAN THE BARBECUE REGULARLY TO AVOID GREASE FIRES.**

### HOW TO AVOID GREASE FIRE

Check the drip tray (13) grease cup (23) after each grilling and clean regularly with a nylon brush and dishwashing detergent. How often it will be necessary to clean will depend on how much and type of food is grilled. To simplify cleaning we recommend adding cat litter and/or aluminum foil on the drip tray.

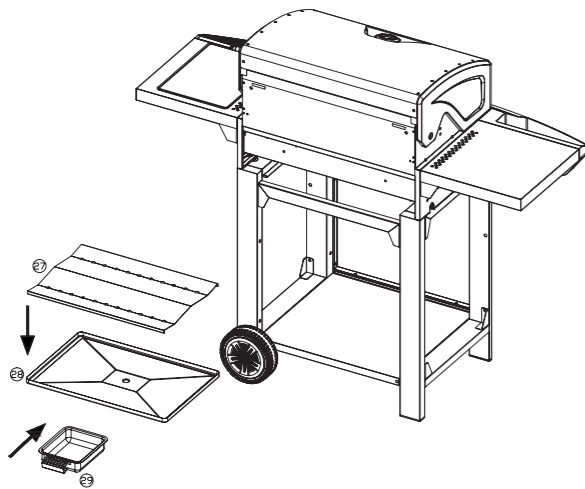

Clean the grill grate after grilling with a grill brush and, if necessary, with soap and water. Clean flame tamers after grilling with a grill brush and, if necessary, with soap and water. In case of visible accumulation of grease and food residue in the firebox, remove these with a plastic scraper or using a nylon brush, water and dish soap. During preheating, check that there are no signs of irregular flames. When grilling foods with much fat or oil, pay extra attention. Feel

free to use trays in aluminum foil to prevent large amounts from running down on flame tamers and on the grease tray. Do not leave the barbecue when it is lit and close the gas supply as soon as possible if there is a sign of a grease fire.

### MAINTENANCE OF THE BARBECUE

- Check regularly that the burners are burning correctly.
- Remove the grill grate and flame tamers
- Light the barbecue in the normal way.
- Turn the control from low to high. Check if there is a difference in strength, and that the flame is clear and blue. The flame should not be orange. If the burner behaves abnormally, read the troubleshooting table.
- Remove grease and old food debris on the burners with a nylon brush and check that no holes in the burner are clogged.

### MAINTENANCE OF THE BURNERS

1. All controls must be in OFF mode. Check that the gas supply is switched off and the regulator is disconnected from the gas container.
2. Remove the cooking grate, flame tamers and drip tray.
3. Remove the screws on the burner, use a screwdriver.
4. Carefully lift the burners out of the valve outlet.
5. Use a nylon brush to clean the outside of the burner.
6. Clean blocked passages / channels by using a metal string or e.g. bending a paper clip.
7. Check that insects, cobwebs etc. do not block the inside of the burner. In that case, remove this.
8. Check if the burner is damaged. Small holes and corrosion can occur with normal use of the barbecue. Are there cracks or holes, the burner should be replaced with a new one.
9. After cleaning, place the burner in place and screw it on.
10. Replace flame tamers, grease trays and grill grate, trays and grill grate.

### CLEANING

All cleaning and maintenance must be performed when the barbecue is cold. Make sure that the gas supply is switched OFF and the regulator is disconnected from the gas container.

Use a mixture of dishwashing detergent and water, or use a separate grill cleaner with a nylon scrubbing brush / scouring sponge on the inside of the lid and in the inner grill body itself. Rinse well and allow to air dry completely. Do not use caustic soda, alcoholic or abrasive detergents. This can damage the barbecue and cause a fire. Cast iron cooking grate, drip tray and grease cup must not be cleaned in a dishwasher.

### PLASTIC PARTS

Use only clean water and any mild detergents. Wipe with a clean cloth.

### COATED AND STAINLESS STEEL PARTS

Inadequate maintenance/cleaning may cause the base, front panel, side table, and other coated or stainless steel parts of the barbecue to begin rusting. To maintain the barbecue's great appearance and surface, it must be regularly cleaned using gentle cleaning agents and warm water to remove salt, grease and other residue that can harm the surface. After washing, dry the surface off with a soft cloth. Make sure the barbecue is completely dry before putting a cover over it.

Coated surfaces must be treated with a polishing agent (e.g., car polish) and stainless steel parts must be treated with a thin layer of acid-free oil one to two times per year. For barbecues kept in coastal areas, we recommend performing treatment more often to prevent salt carried by wind/rain from causing the surface of the metal to rust. Surface rust can be removed by cleaning the surface and applying a polishing agent. Please note that the warranty only covers rust perforation.

### COOKING GRATE OG FLAME TAMERS

Grill grate and flame tamers are brushed regularly with a grill brush for rough cleaning. The grill grate can be soaked in mild soapy water. For difficult, burnt stains, use a non-abrasive cleaner. Rinse well with water and dry well.

**NB!** The barbecue grates must be completely dry before they are placed back in the barbecue. For main cleaning before storing the barbecue for a longer period, feel free to insert the grill grates with a thin layer of cooking oil.

### INSECTS AND VERMIN

After long-term storage, insects and other vermin can be found in the barbecue. If you experience problems with lighting or irregular flames, it can be due to unwanted guests blocking the gas supply. In such instances, dismantle and clean the burners. Replace the burners when they are dry.

- Disassemble the burners and clean them if pests are suspected in the barbecue. Refit the burners when they are completely dry.
- Check that the gas hose is not cracked or damaged by mice or rats.



**FIRES CAUSED BY FAT, DAMAGE THE METAL, PAINT AND ENAMEL. DAMAGE TO THE BARBECUE CAUSED BY FAT BURNING, IS NOT COVERED BY THE GUARANTEE AS IT IS DUE TO INCORRECT USE.**

SCAN QR CODE FOR BARBECUE CLEANING VIDEO



To see how to clean your barbecue, watch our cleaning video: <https://www.youtube.com/watch?v=sC-KW5siUTO&t=1s>

### SAFETY AND INFORMATION

- The gas cylinder should always be placed next to the barbecue when in use.
- Close the gas supply on the regulator when the barbecue is not in use and when storing the gas cylinder under the barbecue, disconnect the regulator.
- If the barbecue is stored in a garage or basement below ground level, the gas cylinder should not be stored in the same place.
- If the barbecue has a side burner, the circumference of the pots and pans used must not be larger than the opening on the side burner. If oversized accessories are used, the heat will be trapped inside which will create an overheating that can damage the barbecue.
- THIS PRODUCT IS INTENDED FOR USE IN PRIVATE HOUSEHOLDS AND IS NOT SUITABLE FOR PROFESSIONAL USE IN A RESTAURANT OR SIMILAR.
- Coatings should not be applied until the barbecue is completely cold and dry. Moisture on the inside of the cover will cause large formations of surface rust for those of the grill parts which are in painted steel and stainless steel.
- AVOID STORAGE OF THE BARBECUE IN DIRECT SUNLIGHT, AS PARTS OF THE BARBECUE THAT CONTAIN STAINLESS STEEL OR GLASS MAY REFLECT SUNLIGHT AND CAUSE FIRE.
- PARTS IN PLASTIC WILL BE ABLE TO BLEACH UNDER THE INFLUENCE OF SUNLIGHT.
- LACQUERED PARTS WILL BE ABLE TO WHITE WITH THE EFFECT OF SUNLIGHT.

### ADVICE AND TIPS

- Always preheat the barbecue for 10-15 minutes before starting to grill. Then the cast iron grates are taken up and distributed evenly over the barbecue surface.
- Outdoor temperature, wind, snow and rain can give a deviation of up to 30% on the temperature shown in the thermometer and the temperature that is actually on the barbecue surface.
- Avoid placing food all the way to the edge (approx. 1.5 cm) on the grill grate. Grease that runs down the side walls of the grill room will be able to drip onto the surface.
- Make sure that the barbecue is on a stable and straight surface to prevent grease from leaking out of the grease collection system.
- To facilitate cleaning of grease trays, cat litter can be used to absorb grease.
- Make sure that the barbecue is stored dry under a roof or under a cover. Water from snow, ice and rain that enters the barbecue can overflow the grease collection system and cause leakage to the surface.
- We recommend the use of FCC BBQ original covers for the best possible protection against rain, pollen and pollution. Remember that the barbecue must be completely dry and cold before applying the coating. The coating is equally waterproof both ways and moisture on the inside can cause major rust damage on painted and stainless steel surfaces.



PROBLEM	POSSIBLE CAUSE	SOLUTION
BURNER WILL NOT LIGHT	Gas cylinder is empty	Replace gas cylinder
	Damaged regulator	Check/replace the regulator
	Burner is blocked	Clean the burner
	Gas supply is blocked	Clean gas ventury or hose
	Electrode is broken or dirty	Clean the electrode
	Ignition knob is broken	Contact your dealer
	Windy conditions	Place the BBQ in a less exposed position
	Ignition wire is damaged or fitted incorrectly	Make sure wire is mounted correct
BURNER WILL NOT LIGHT WHEN PERFORMING MANUAL LIGHTING	Empty gas cylinder	Replace gas cylinder
	Irregular gas supply	Check/replace the regulator
	The burner is blocked	Clean the burner
	Gas supply or hose is blocked	Clean gas ventury or hose
LOW FLAME OR BACKFIRE	Gas cylinder is too small	10 kg or larger cylinder is recommended
	Burner is blocked	Clean the burner
	Gas supply or hose is blocked	Clean gas ventury or hose
	Windy conditions	Place the BBQ in a less exposed position
TROUBLE TURNING THE KNOBS	Gas valve jammed	Replace gas valve. NB! Knobs should be pressed in and turned
HEAVY SMOKE	Fatty foods on the BBQ	Trim away excess fat from meat. Clean the fat tray
BEEPING SOUND WHEN THE GAS IS BURNING	Twisted flex hose	Straighten out the flexible hose by the side burner. If the hose is bent, the barbecue can make a beeping sound

## Consumer Contact

This product is covered by a warranty in accordance with consumer legislation. It has undergone strict quality controls and testing at the factory. If there are any parts missing or the product has been damaged, please contact your dealer or the consumer contact below for help.

In the event of damage to the product, we ask for pictures of the damage and damage to the product's packaging is attached to the complaint.

Faults due to misuse, lack of maintenance or modification of the product will invalidate the warranty. Damaged parts not due to a fault with the product will be invoiced according to our price list + carriage and administration fee.

If new parts are needed or in the event of a warranty claim, please contact your dealer or consumer contact:

### FCC PRODUCTS AS

KJELLER VEST 3, 2007 KJELLER, NORWAY

☎ +47 924 78 600 / +46 031 189095 (MON-FRI 10:00-14:00)

✉ support@fccbbq.com

FCCBBQ.NO

FCCBBQ.SE

FCCBBQ.COM

Always attach your receipt and product serial number when making a warranty claim. Serial number is located on the bottom plate BBQ.

**Produced in China for FCC Products**

We are always looking for ways we can improve our products. Therefore, we reserve the right to change technical specifications at any time. You will always find the latest manual on [www.fccbbq.no](http://www.fccbbq.no).