

The Flying Culinary Circus

FCCBBQ



Barrel

INSTRUCTION MANUAL & MAINTENANCE



FCC-C-20575

OUTDOOR USE ONLY

READ THE OPERATING INSTRUCTIONS AND WARNINGS BEFORE USING THE APPLIANCE.



Share the fun of cooking!

Read carefully

WARNING

- FAILURE TO FOLLOW THE INSTRUCTIONS PROVIDED CAN IMPLY A RISK OF SERIOUS INJURY TO PERSONNEL AND FIXED INSTALLATIONS.
- THE BBQ IS INTENDED FOR OUTDOOR USE ONLY IN WELL-VENTILATED AREAS. NEVER BBQ IN CLOSED SPACES OR UNDER A ROOF, DUE TO THE DANGER OF LACK OF OXYGEN.
- ACCESSIBLE PARTS OF THE BBQ BECOME VERY HOT DURING USE. KEEP CHILDREN AND OTHERS WHO NEED SUPERVISION AT A SAFE DISTANCE.
- NEVER MOVE THE BBQ WHILE IN USE.
- CLEAN THE BBQ REGULARLY AND THOROUGHLY.

WARNING

DANGER OF CARBON MONOXIDE POISONING

BURNING CHARCOAL INDOORS CAN BE FATAL. CARBON MONOXIDE IS RELEASED - AN ODOURLESS GAS. NEVER BURN CHARCOAL IN A CLOSED AREA, SUCH AS A DWELLING, CAR OR TENT.

FAILURE TO COMPLY WITH THE INSTRUCTIONS AND WARNINGS IN THIS MANUAL, AND TO EXERCISE CAUTION WHEN USING THE BBQ, CAN CAUSE FIRE, EXPLOSION, SERIOUS INJURY OR DEATH, IN ADDITION TO MATERIAL DAMAGE.

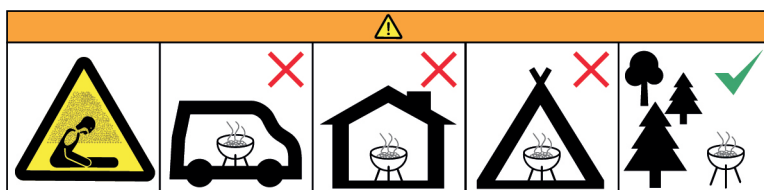

EN: WARNING!
Do not use spirit or petrol for lighting or re-lighting!

- For outdoor use only! Do not use under awnings, canopies, parasols or the like.
- Place BBQ on a firm, even and stable surface at a safe distance from buildings, trees and other flammable materials.
- Never move the BBQ when in use.
- The BBQ can be extremely hot when in use.
- Use BBQ gloves or other heat-resistant gloves when grilling to avoid burns.
- Only use grill implements made of heat-resistant materials.
- We recommend using grill lighter briquettes, for the most effective, clean and safe way to start your BBQ. If using lighter fluid, do not ignite if there is any fluid on the outside of the BBQ, the area around it, on your own clothes etc.
- Do not use ethanol or petrol to light or relight charcoal or lighter briquettes. When using fluids to start a BBQ, ensure they are approved according to EN 1860-3.
- Never relight the BBQ with any form of fluid, not even lighter fluid, as the charcoal can still be smouldering and cause large flames, a fire hazard and damage the BBQ.
- Always check that charcoal or briquettes are fully extinguished before removing ash.
- Never leave a BBQ in use or that has just been used without ensuring that all charcoal is fully extinguished.
- Always empty used charcoal/briquettes into a metal container. Never pour used charcoal/briquettes directly onto the ground.
- Flames can shoot up if hot fat or food falls on to burning charcoal/briquettes. Always have water available to put out any such flames.
- Do not use the BBQ in strong winds.
- Always have a bucket of water to hand when grilling.
- Wait until a white layer of ash covers the charcoal/briquettes before grilling.
- Do not empty used charcoal or briquettes back into the pack.
- Keep charcoal and briquettes dry and well ventilated and at a safe distance from heat sources.



WARNING! KEEP CHILDREN, ANIMALS AND OTHERS WHO NEEDS SUPERVISION AT A SAFE DISTANCE FROM THE GRILL. THE GRILL CAN BE EXTREMELY HOT.

WARNING! NEVER MOVE THE GRILL ONCE LIT OR WHILE IT IS STILL HOT.

WARNING! DO NOT TOUCH THE GRILL BODY WHEN LIT, IT CAN BE EXTREMELY HOT AND THERE IS A RISK OF BURNS.

WARNING! DO NOT USE FLUIDS SUCH AS SPIRITS, PETROL, DIESEL, PARAFFIN OR ALCOHOL FOR LIGHTING OR RELIGHTING THE GRILL. WE RECOMMEND THE USE OF LIGHTING BRIQUETTES.

Prior to barbecuing

LOCATION

- ◆ Ensure that the BBQ is placed at least 150cm in all directions from house walls, trees, plants and other flammable materials or liquids when in use.
- ◆ Do not place the BBQ under a roof or overhang
- ◆ Ensure the BBQ is placed where there is plenty of ventilation.
- ◆ Do not BBQ below normal ground level.

Lighting methods

LIGHTER BRIQUETTES

- ◆ Place charcoal/briquettes in a pyramid.
- ◆ Place 2 - 3 lighting briquettes between the charcoal and carefully light them with a match.
- ◆ Once the charcoal/briquettes are burning and the flames/smoke have subsided, spread them over the charcoal grate. Never use your fingers, plastic implements or flammable objects to move burning charcoal. Use grill implements.
- ◆ Check that the grate is correctly positioned.
- ◆ Put on more charcoal when needed.

LIGHTER FLUID

We do not recommend using lighter fluid for several reasons:

- ◆ It can cause large flames and increase the chance of burns.
- ◆ It collects in the bottom of the grill and can cause large flames after the grill has been alight for a while.
- ◆ Large amounts of fluid in the bottom of the grill can cause a lot of flames that can damage the grill surface.
- ◆ Fluid that leaks out of the grill can burn the exterior of the grill.
- ◆ Charcoal/briquettes soaked in fluid and lit before the fluid has soaked in properly can cause large flames and burns. excessively large flames can also damage the grill surface.

Amount of Charcoal



NEVER OVERFILL THE GRILL WITH CHARCOAL/BRIQUETTES, AS IT MAY DAMAGE THE GRILL ENAMEL. DAMAGE CAUSED BY INCORRECT USE IS NOT COVERED BY THE WARRANTY.







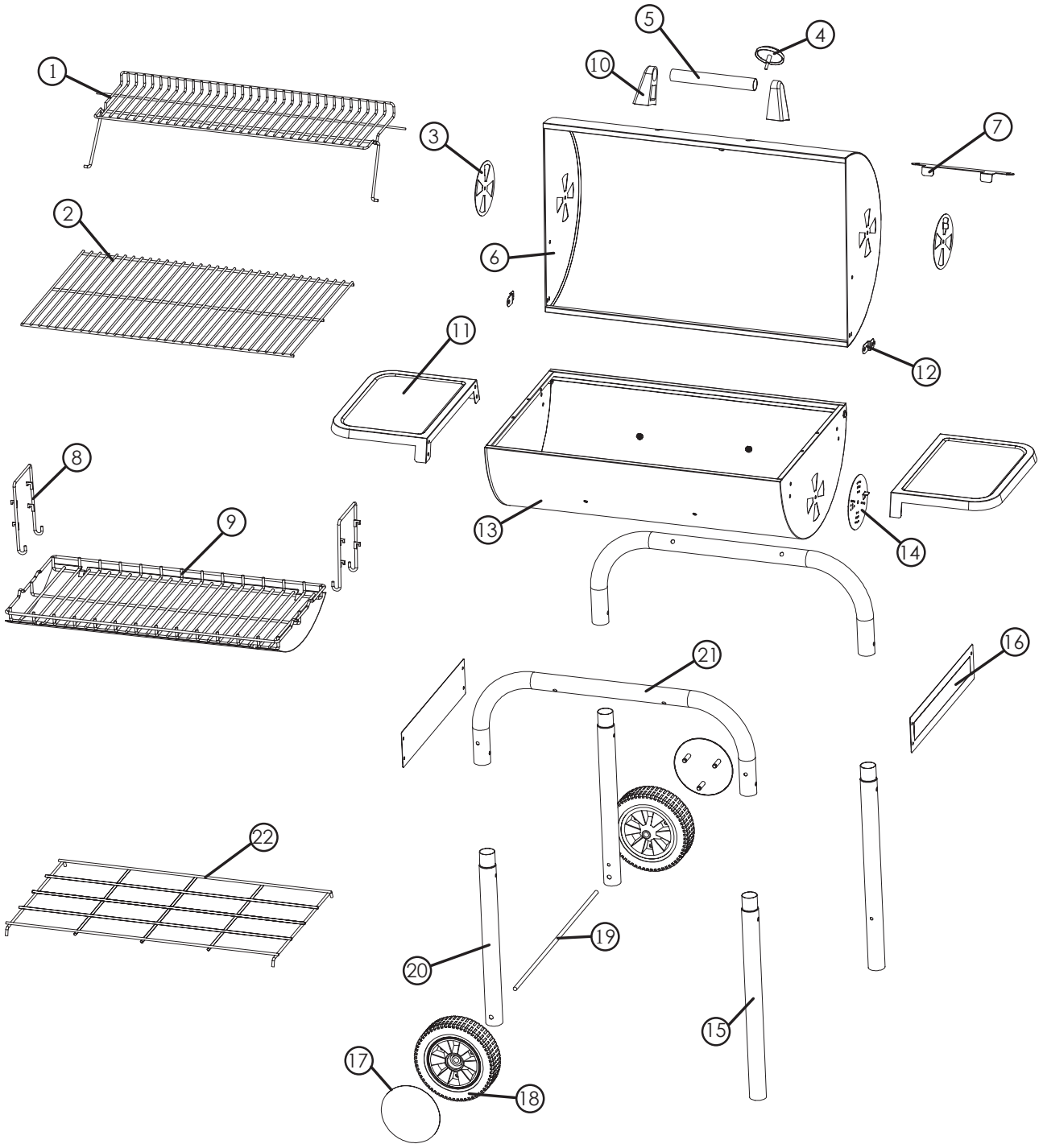

AMOUNT OF CHARCOAL /BRIQUETTE





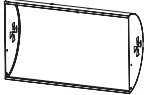
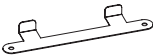

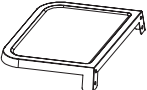
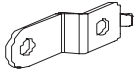

RECOMMENDED AMOUNT OF CHARCOAL	1.3 KG
MAX AMOUNT OF CHARCOAL	1.7 KG
RECOMMENDED AMOUNT OF BRIQUETTES	2.0KG
MAX AMOUNT OF BRIQUETTES	2.2 KG

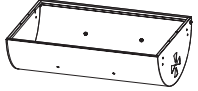
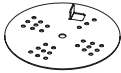
Exploded Drawing





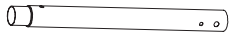



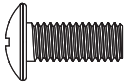

Parts List

No.	Description	Qty	Image
1	Warming Rack	1	
2	Cooking Grill	1	
3	Lid Air Vent	2	
4	Temperature Gauge	1	
5	Lid Handle	1	
6	Grill Lid	1	
7	Lid Stop Handle	1	
8	Charcoal Grate Hangers	2	
9	Charcoal Grate	1	
10	Handle Attachment	2	
11	Side Table	2	
12	Side Table Bracket	2	

No.	Description	Qty	Image
13	Grill Body	1	
14	Body Air Vent	1	
15	Long Leg	2	
16	Leg Support	2	
17	Wheel Cover	2	
18	Wheel	2	
19	Axle	1	
20	Wheel Leg	2	
21	Bend Leg	2	
22	Bottom Shelf	1	

Hardware

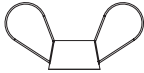
A	M6x12 Screw	19	
B	M6 Washer	24	
C	M6x45 Screw	12	
D	M6 Nut	24	

E	M6 Lock Washer	15	
F	M8 Nut	2	
G	M6 Wing Nut	3	
H	M8 Washer	2	

Assembly

STEP 1.

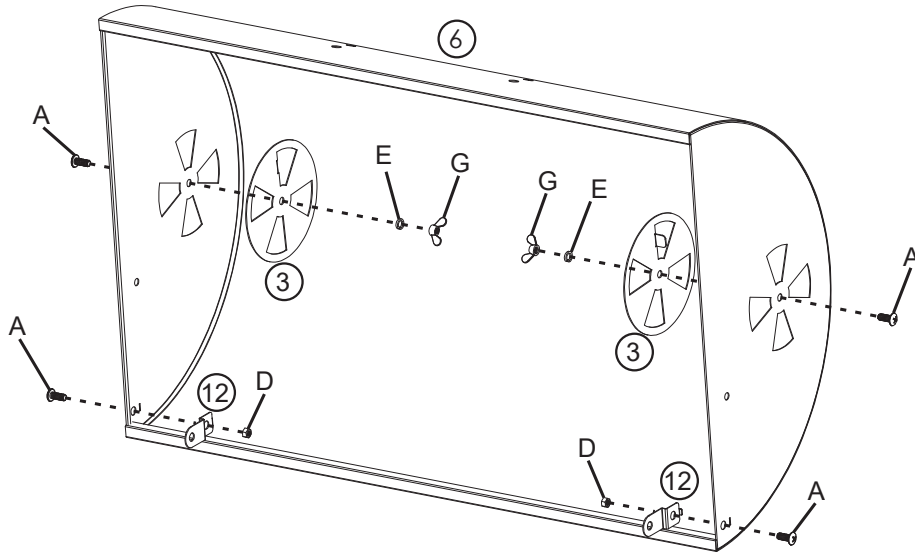

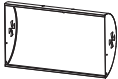

③ 2x 

⑥ 1x 

⑫ 2x 

A 4x 

D 2x 

E 2x 

G 2x 

STEP 2.

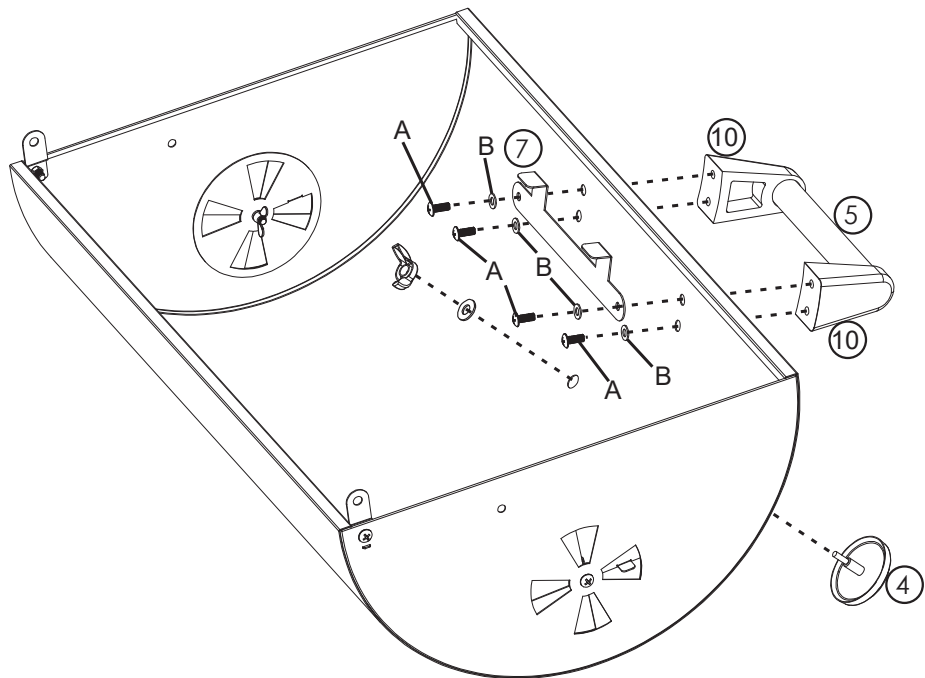



④ 1x 

⑤ 1x 

⑦ 1x 

⑩ 2x 

A 4x 

B 4x 

Assembly

STEP 3.

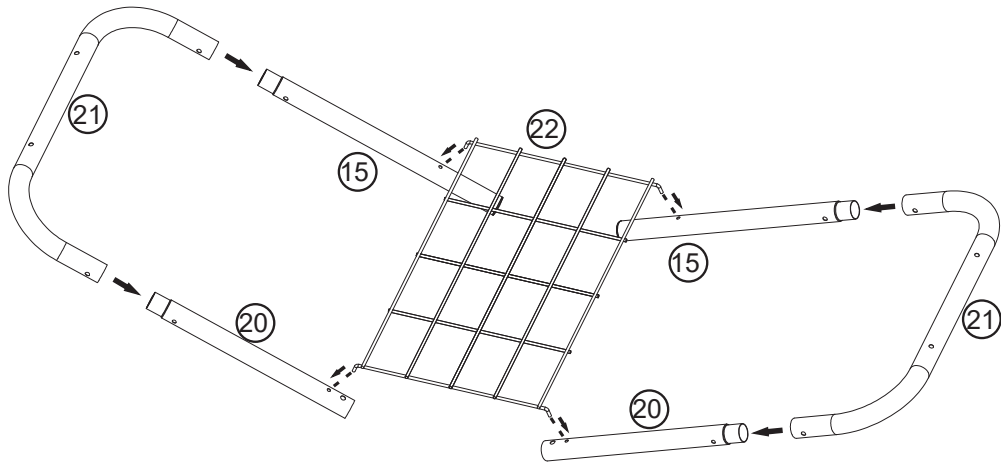

- ⑮ 2x
- ⑯ 2x
- ⑰ 2x
- ⑱ 1x

STEP 4.

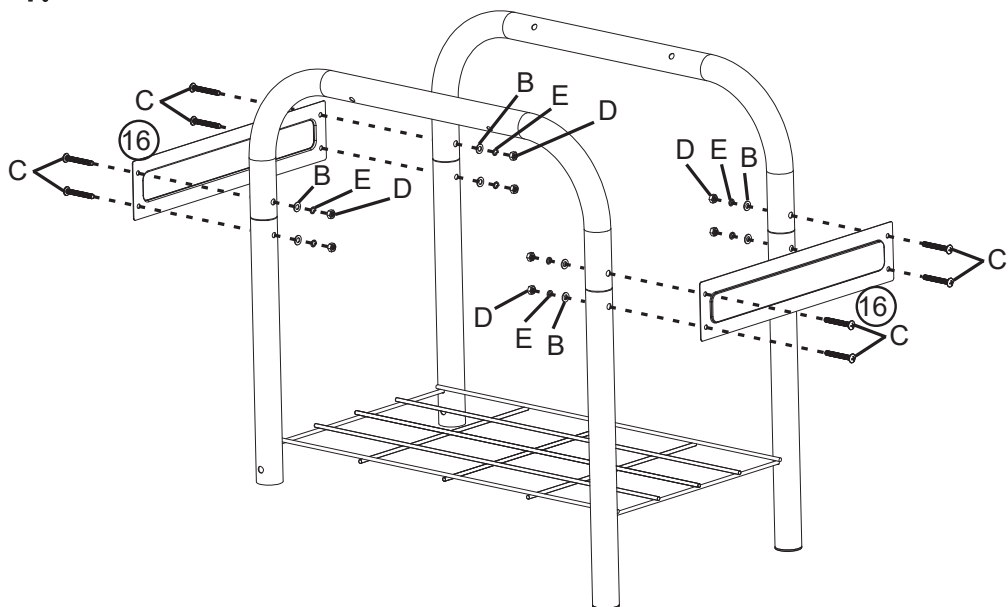



- ⑲ 2x
- C 8x
- B 8x
- D 8x
- E 8x

Assembly

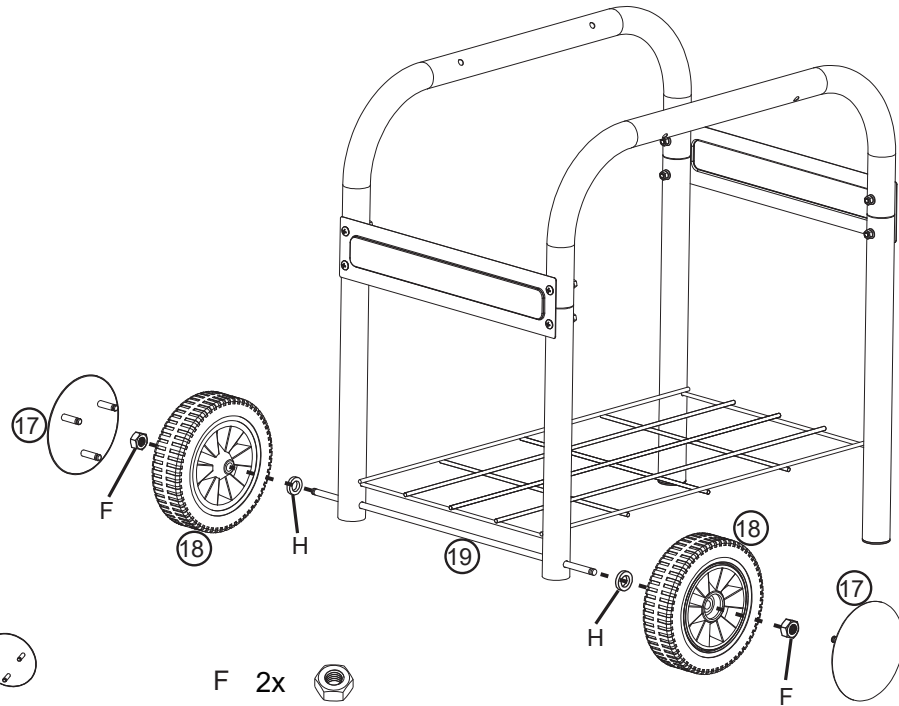
STEP 5.



17 2x 

F 2x 

18 2x 

H 2x 

19 1x 

STEP 6.

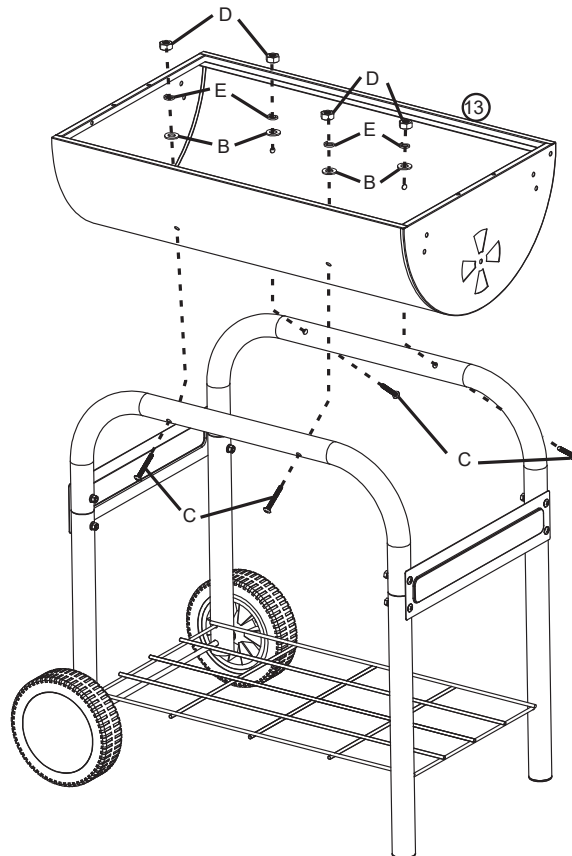

1x 

C 8x 

B 8x 

D 8x 

E 8x 

Assembly

STEP 7.

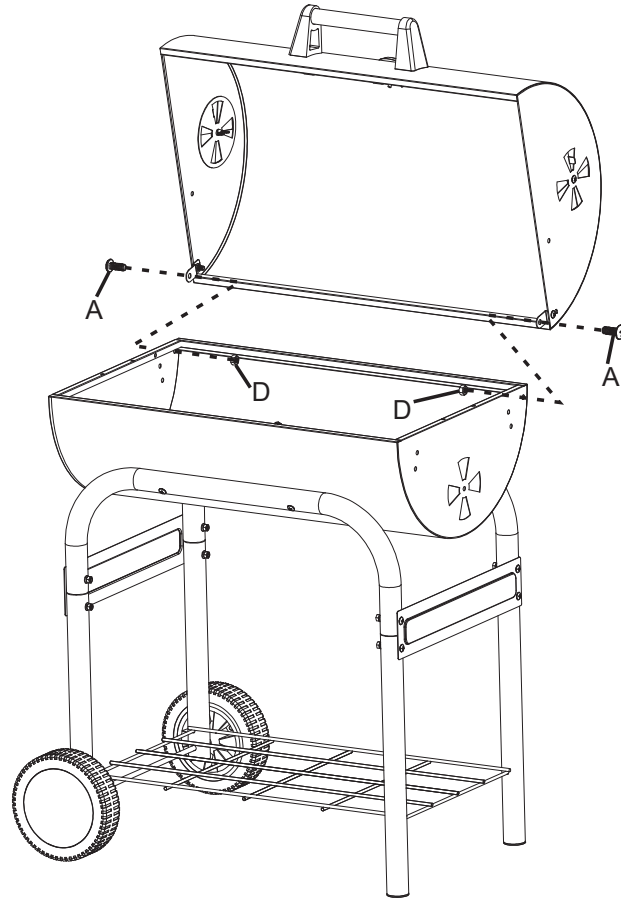

- A 2x
- D 2x

STEP 8.

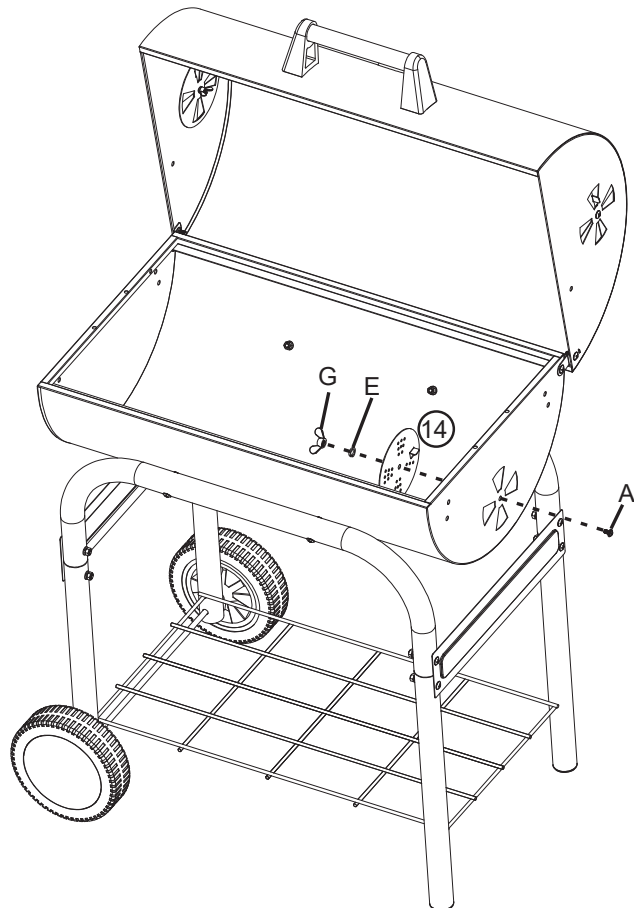

- ⑭ 1x
- A 1x
- E 1x
- G 1x

Assembly

STEP 9.

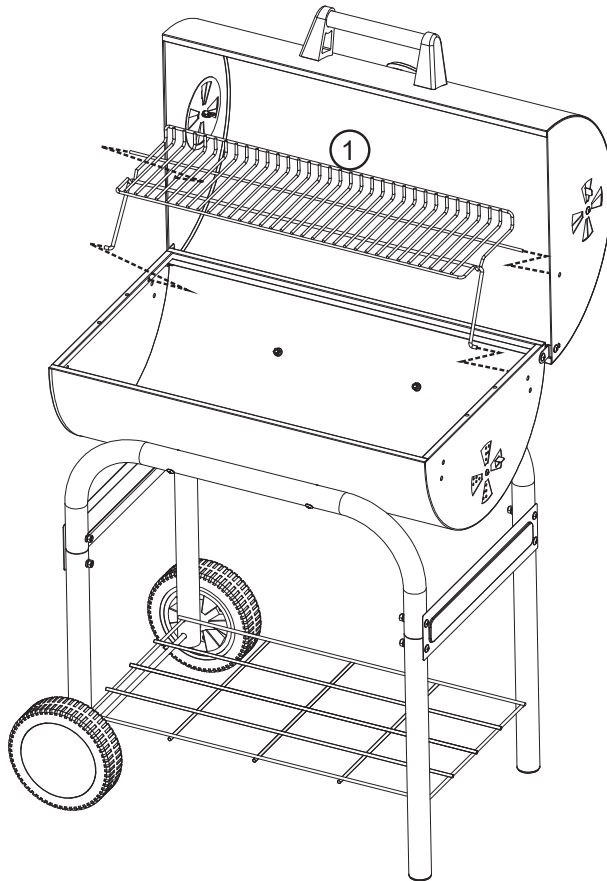

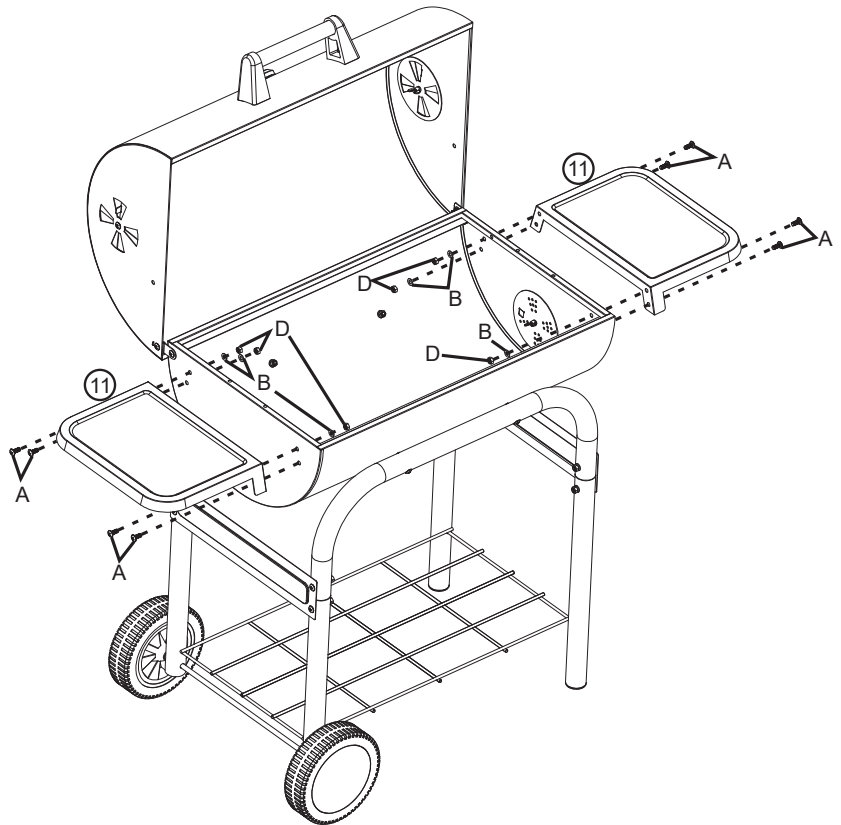

① 1x 

STEP 10.



⑪ 2x 

A 8x 

B 8x 

D 8x 

Assembly

STEP 11.

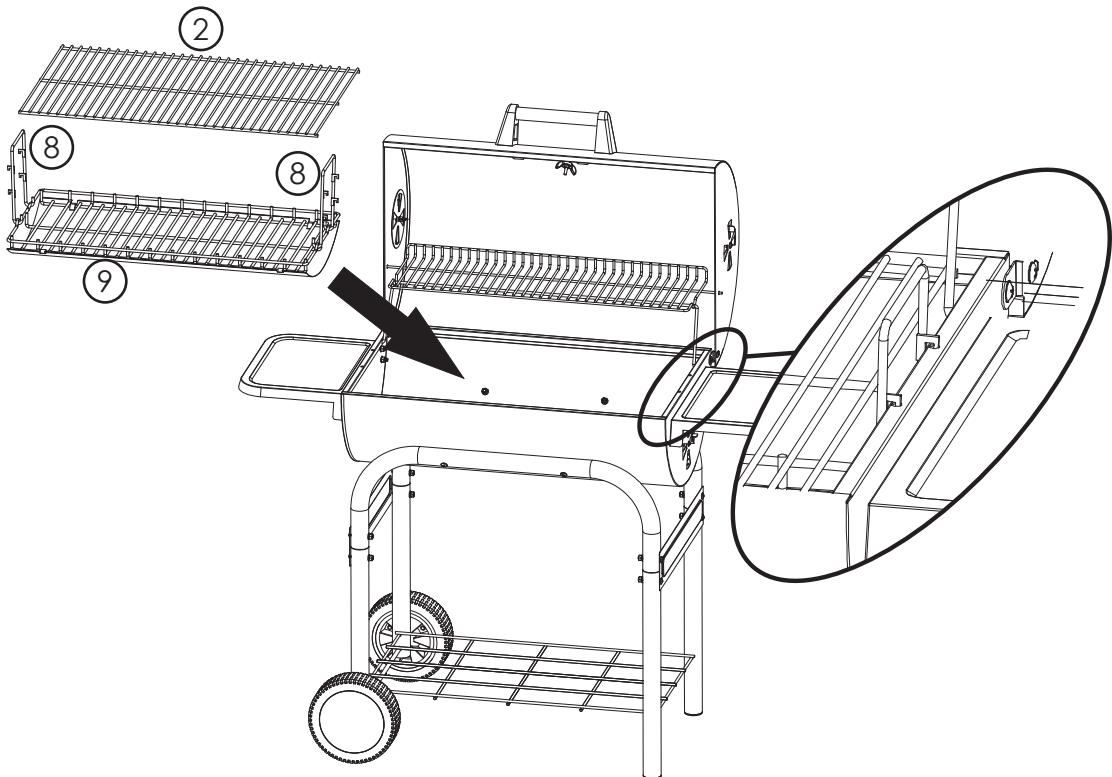

② 1x 

⑧ 2x 

⑨ 1x 

During barbecuing

- ◆ For the correct amount of charcoal/briquettes – see page 5 of this manual.
- ◆ Do not overfill the grill with charcoal/briquettes. The grill can get too hot for cooking and the heat can represent a risk to people or animals in the vicinity.
- ◆ Using too much charcoal can also damage the grill surface and thus the paint/enamel. Paint and enamel are applied to protect the grill and damage can cause rust.
- ◆ The grill can be extremely hot when in use. Use grill gloves when grilling.
- ◆ If flames should appear during use - due to fat, marinade or the like dripping on to the charcoal - we recommend using a spray bottle to spray a little water on the charcoal.
- ◆ When finished using the grill, do not douse the charcoal with large amounts of COLD water, as this can damage the paint/enamel. Use sand or spray small amounts of water gradually and repeatedly.
- ◆ Always check that all embers are extinguished before removing used charcoal/briquettes. This can take up to 24 hours. Always dispose of ash and charcoal residue where they cannot cause fire.

Maintenance

- ◆ To make cleaning your grill easier, cover the inside with aluminium foil before pouring the charcoal in and using the grill. Use with the shiny side up. Remember to make holes in the foil for ventilation where necessary.
- ◆ Wash the grill grate in hot soapy water as soon after grilling as possible. Dry the grate well and store in a dry place when not in use. We recommend coating the grate with food oil after cleaning, between each grilling and before storing.
- ◆ When storing the grill outdoors, keep it covered. Alternatively, the grill can be stored indoors, in a garage or under a roof.
- ◆ **WARNING!** Always check that all the charcoal is extinguished and that there are no embers left before putting the grill away for storage.
- ◆ It is important that grill and grates are cleaned after every use and before putting it into long-term storage. Residues of marinade, fat etc. can cause mould and accelerate rust.
- ◆ We recommend repairing cracks or scratches in the paint or enamel with heat-resistant paint as soon as possible. Stocked by ironmongers, builder's merchants, paint shops, workshops etc. Repair any rust as soon as possible before it spreads.

GOOD ADVICE

★ A CLEAN BBQ WORKS BETTER, causes less smoke and will last longer.

★ PREHEAT THE BBQ to make sure the charcoal/briquettes are grey prior to placing food on the BBQ. This gives a better result, and cuts BBQing time.



Our story

In 2005 four talented young chefs left for New York, asked to cook at an event in Central Park. They enjoyed working together and the guests really appreciated the food. One of the guests was so enthusiastic he booked the four chefs for another event in Los Angeles.

The idea of “The Flying Culinary Circus” was created.

Fast forward – The chefs have now travelled to more than 65 countries all over the world. Royalties as well as celebrities have enjoyed the culinary concept the chefs offer tremendously. But, as the chefs say “it’s not about how famous our guests are, it is all about sharing the fun of cooking».

Consumer Contact

This product is covered by a warranty in accordance with consumer legislation. It has undergone strict quality controls and testing at the factory.

If there are any parts missing or the product has been damaged, please contact your dealer or the consumer contact below for help.

Faults due to misuse, lack of maintenance or modification of the product will invalidate the warranty. Damaged parts not due to a fault with the product will be invoiced according to our price list + carriage and administration fee.

If new parts are needed or in the event of a warranty claim, please contact your dealer or consumer contact:

FCC PRODUCTS AS
KJELLER VEST 3, 2007 KJELLER, NORWAY

+47 924 78 600
✉ support@fccproducts.no
www.fccproducts.no

Always attach your receipt when making a warranty claim.

Produced in China for FCC Products AS

We are always looking for ways we can improve our products. Therefore, we reserve the right to change technical specifications at any time. You will always find the latest manual on www.fccproducts.no.